

# Réaménagement de l'avenue Firmin Lecharlier

Présentation citoyenne : 28 juin 2022

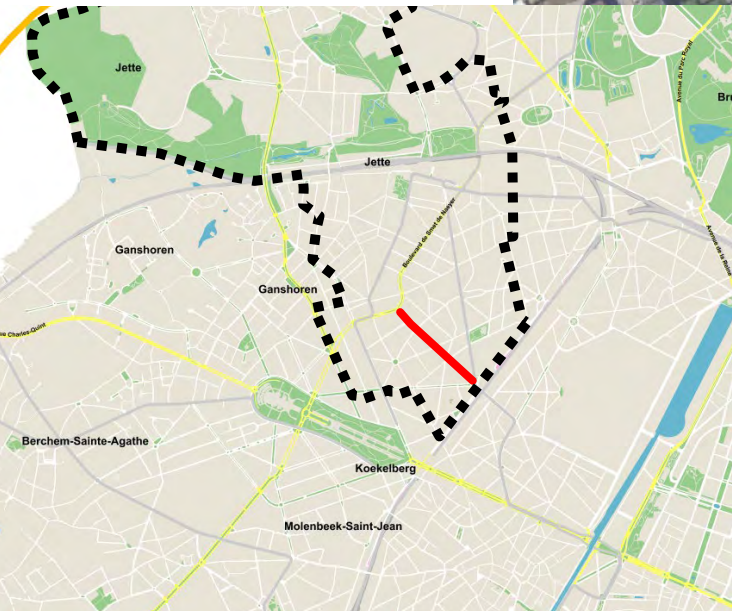

# Plan de localisation



# Séquence 1

## du boulevard Smet De Naeyer à l'avenue Odon Warland

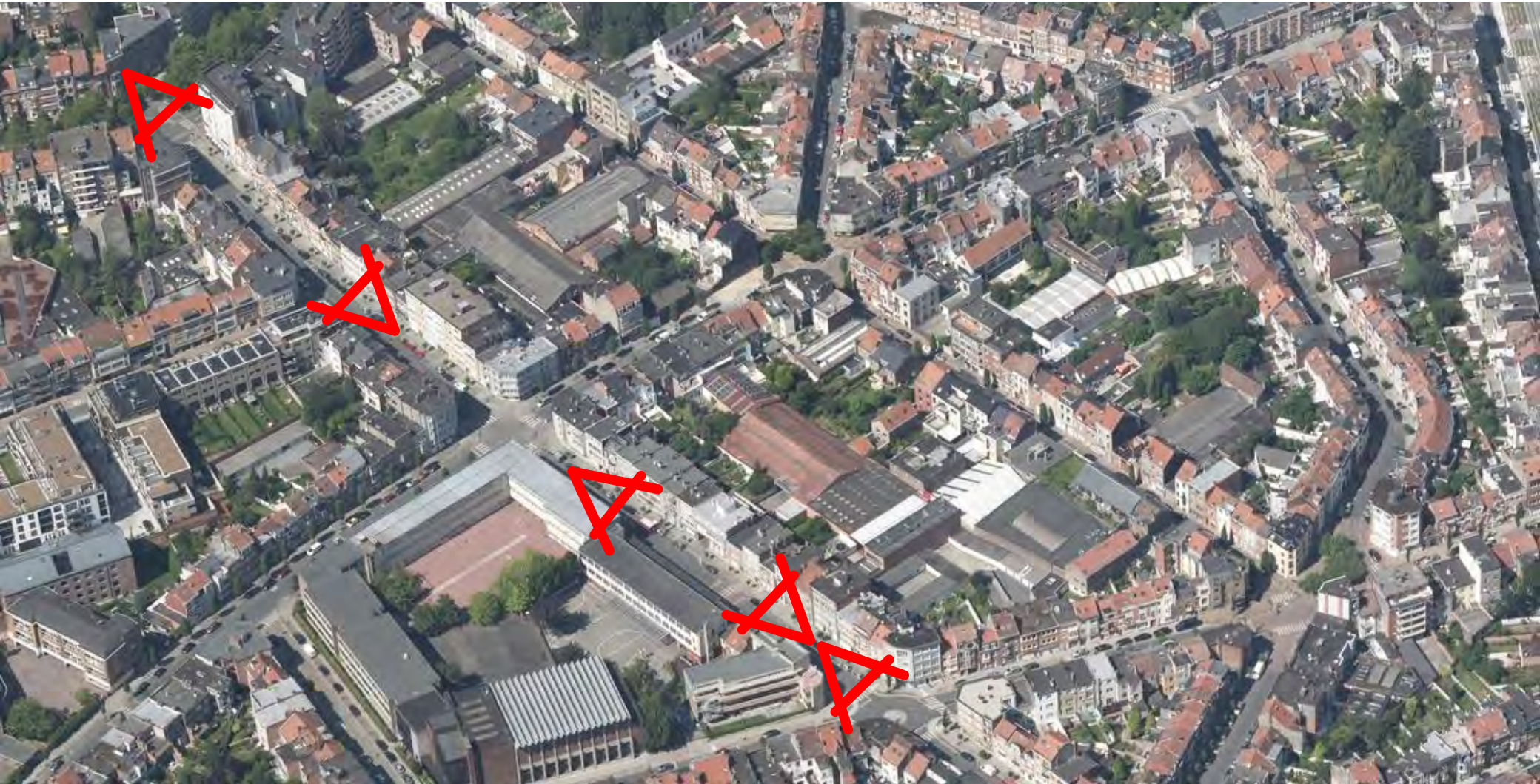

# Photos de l'avenue Firmin Lecharlier

## Séquence 1



Depuis le boulevard Smet  
De Naeyer



Vers le boulevard Smet  
De Naeyer



Athénée Royal de  
Jette



Ecole Fondamentale  
Communale « Clarté »

# Photos de l'avenue Firmin Lecharlier

## Séquence 1



# Séquence 2

## de l'avenue Odon Warland à la Place Philippe Werrie

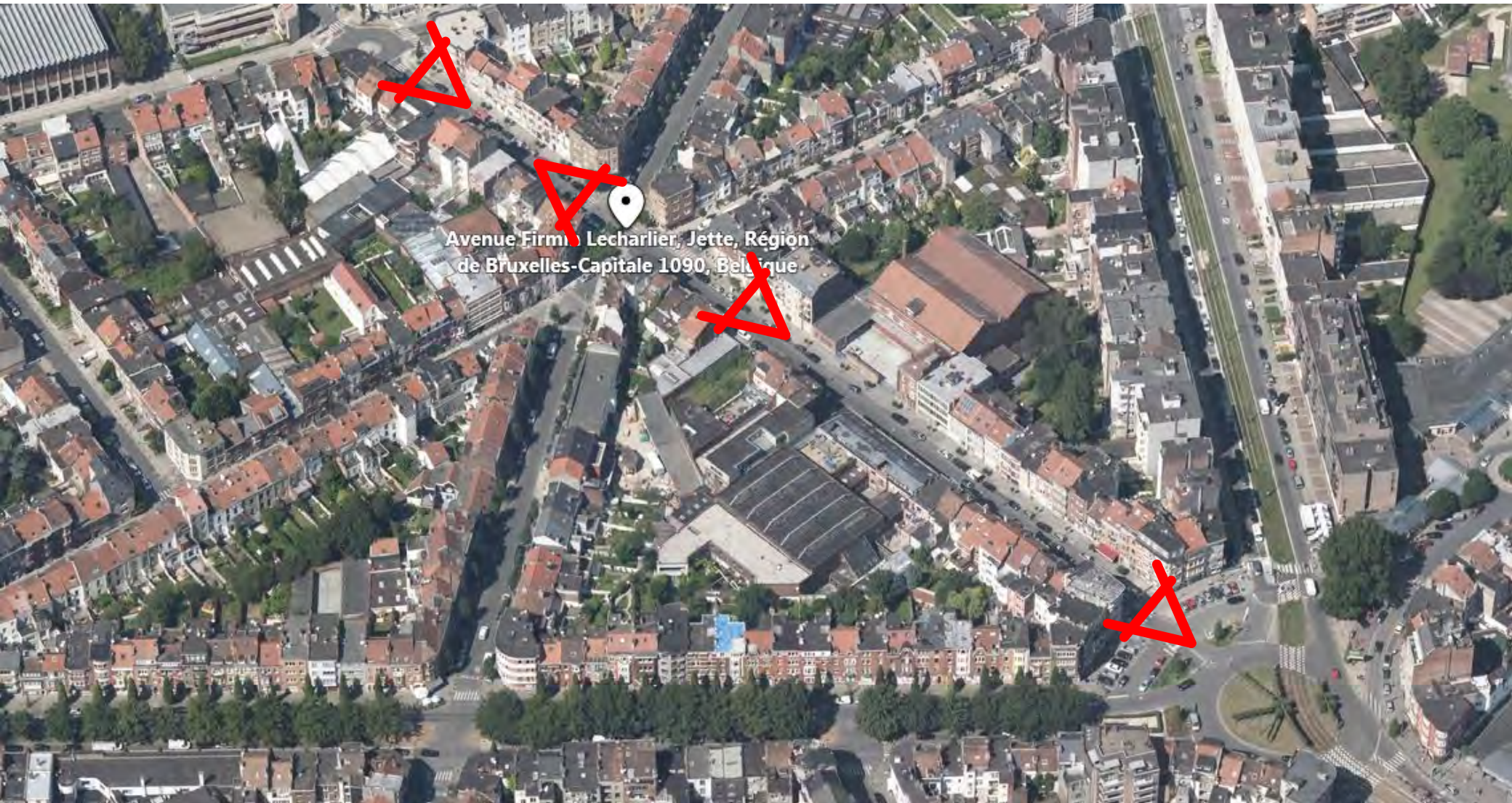

# Photos de l'avenue Firmin Lecharlier

## Séquence 2



Depuis la place Philippe  
Werrie



vers  
le carrefour Moranville#Procureur#Longtin



Depuis le carrefour Moranville#Procureur#Longtin  
vers la place Philippe Werrie



vers Odon Warland

# Photos des rues aboutissantes sur l'avenue Firmin Lecharlier



Rue Léopold Procureur



Rue Honoré Longtin  
(côté numéro pair)



Rue Honoré Longtin  
(côté numéro impair)



Avenue Odon Warland  
(côté numéro pair)



# Photos des rues aboutissantes sur l'avenue Firmin Lecharlier



Avenue Odon Warland  
(côté numéro impair)



Avenue Levis Mirepoix  
(côté numéro pair)



Avenue Levis Mirepoix  
(côté numéro impair)



Avenue Paul De Merten

# Affectations du Sol

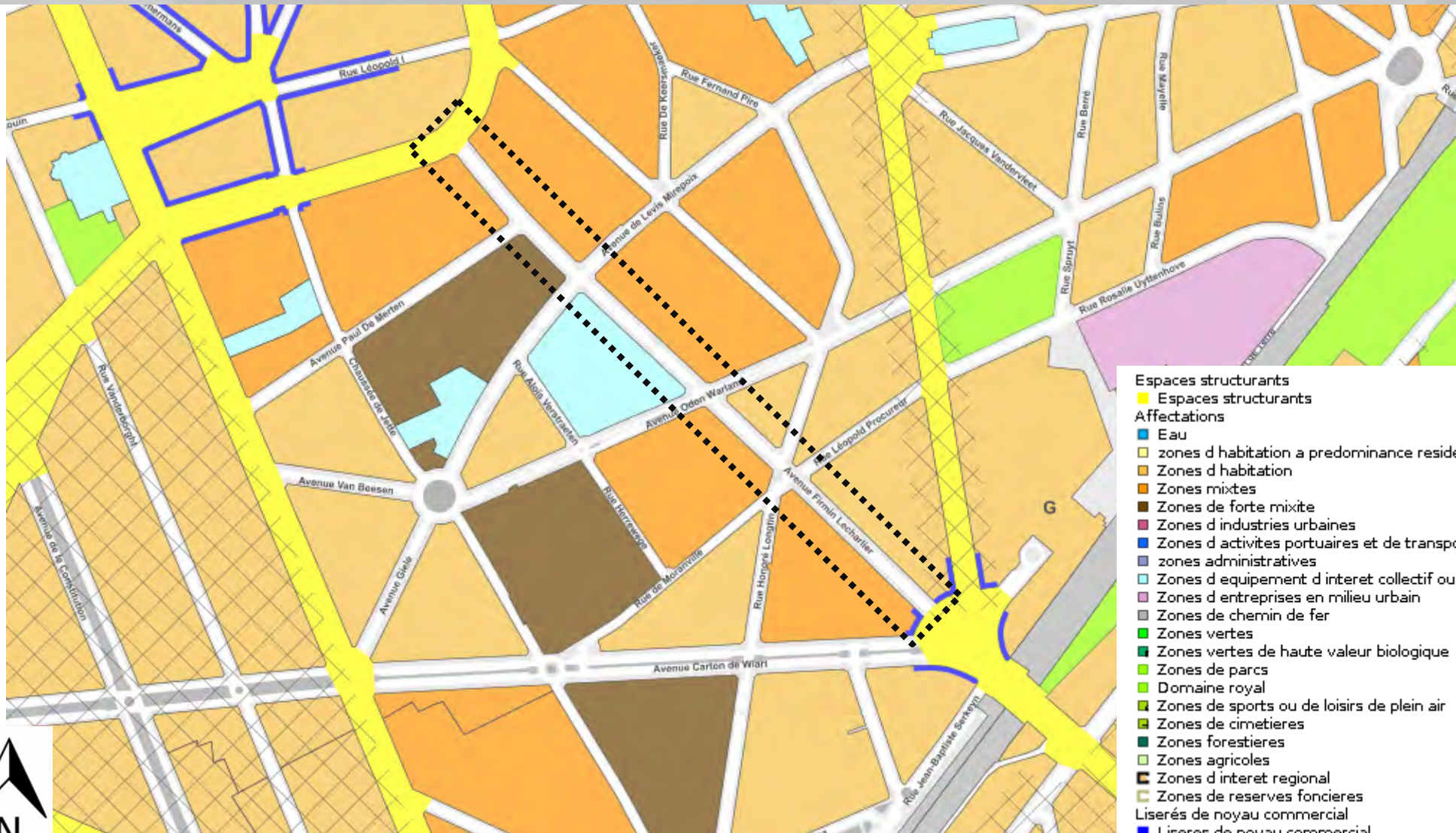

- Espaces structurants**
- Espaces structurants
- Affectations**
- Eau
- zones d habitation a predominance residentielle
- Zones d habitation
- Zones mixtes
- Zones de forte mixite
- Zones d industries urbaines
- Zones d activites portuaires et de transports
- zones administratives
- Zones d equipement d interet collectif ou de se
- Zones d entreprises en milieu urbain
- Zones de chemin de fer
- Zones vertes
- Zones vertes de haute valeur biologique
- Zones de parcs
- Domaine royal
- Zones de sports ou de loisirs de plein air
- Zones de cimetières
- Zones forestieres
- Zones agricoles
- Zones d interet regional
- Zones de reserves foncieres
- Liserés de noyau commercial**
- Liseres de novau commercial



PRAS - Brugis

# Plan directeur bus – Réseaux TRANSPORT PUBLIC

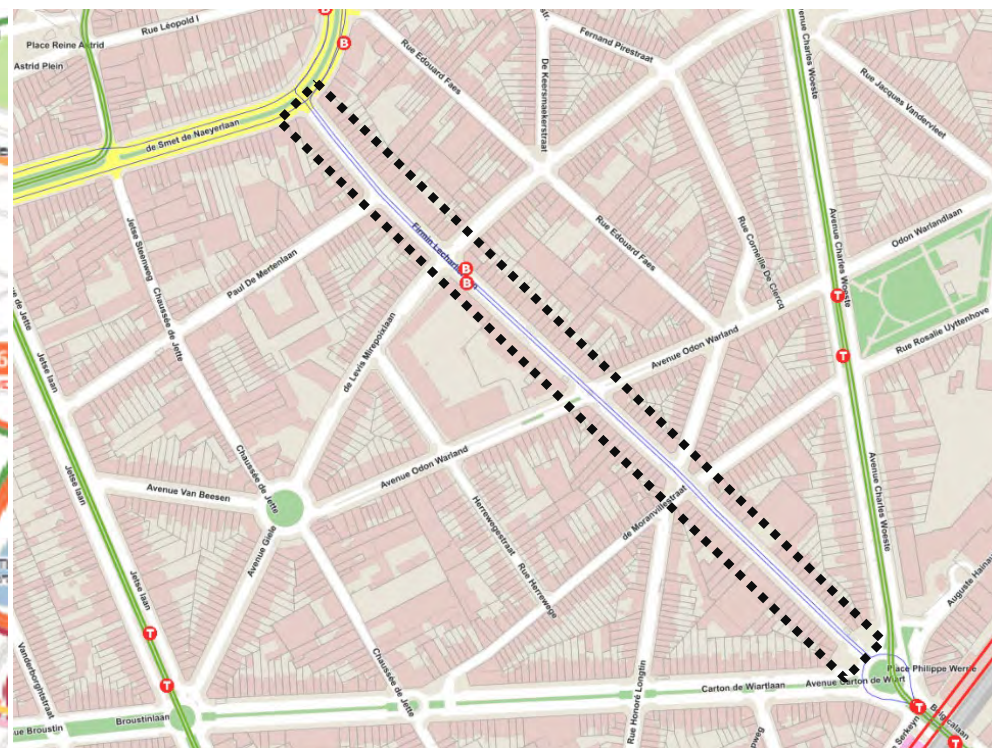

Bus ligne 14  
Heysel-Gare du Nord  
5 bus/heure

# Réseaux cyclables

## ICR – Itinéraire Cyclable Régional

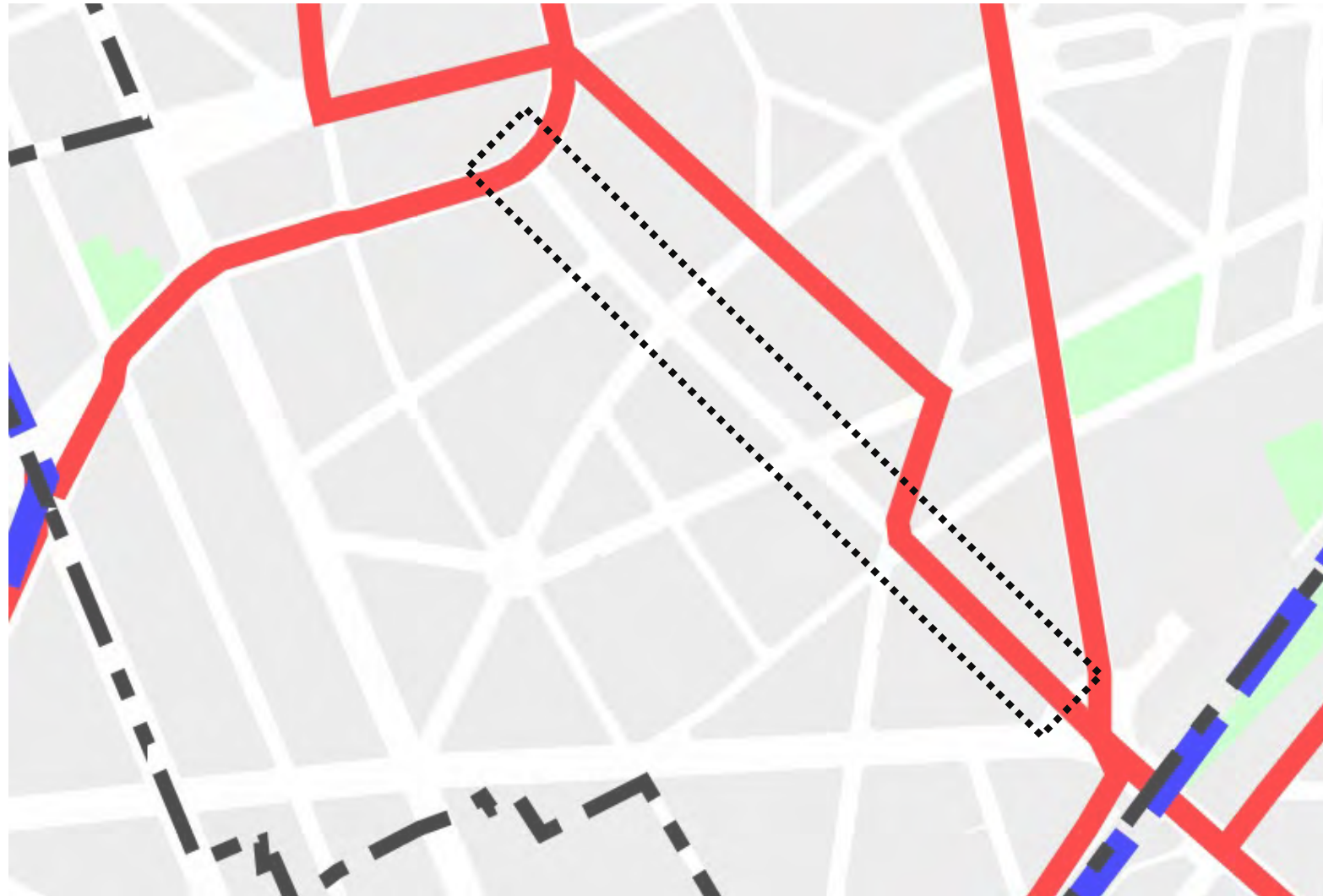

# Good Move

## Réseaux et trafic

SMV Piétons  
**PLUS** et  
**CONFORT**

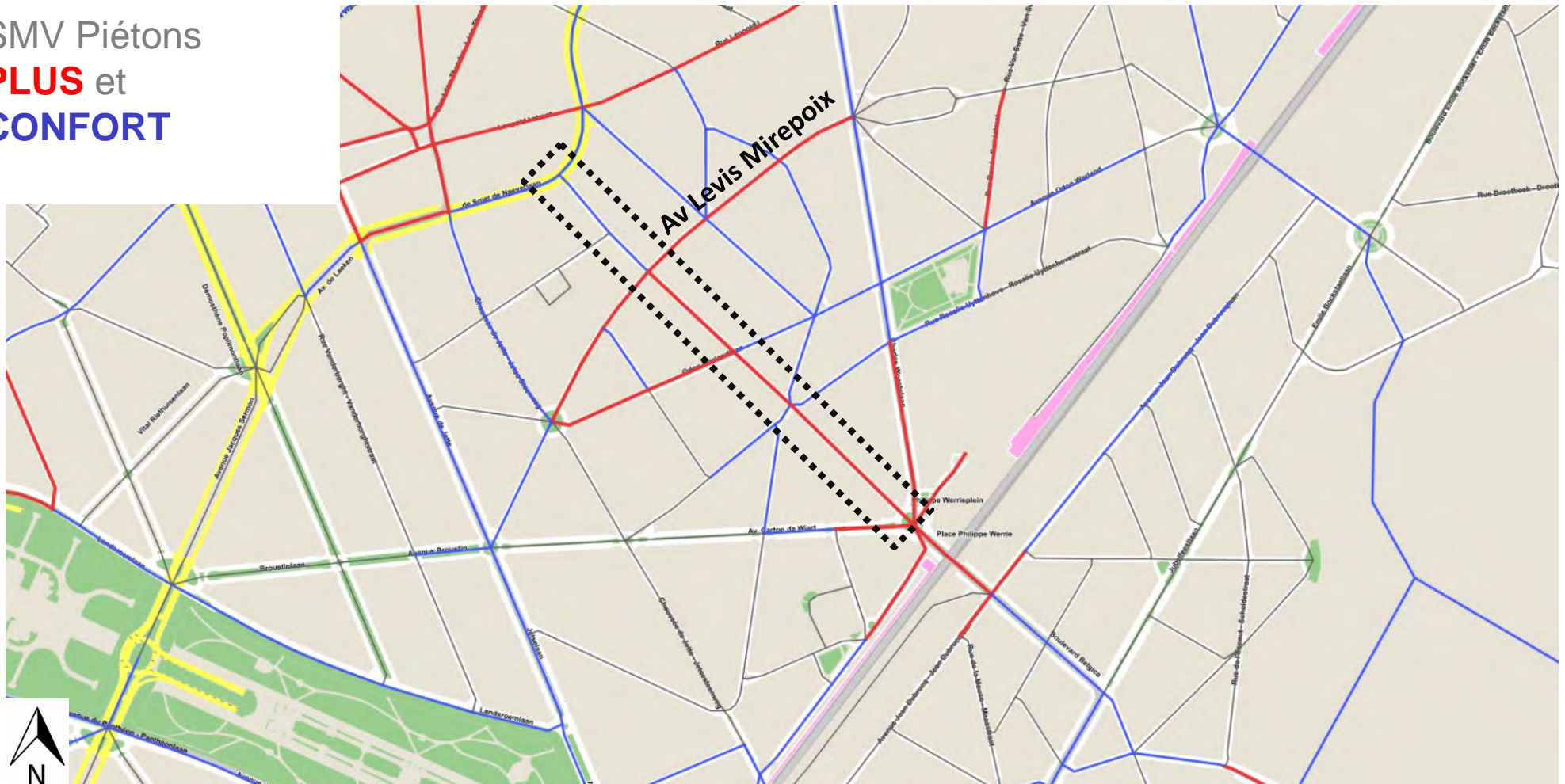



# Good Move

## Réseaux et trafic

SMV Transport  
public  
QUARTIER

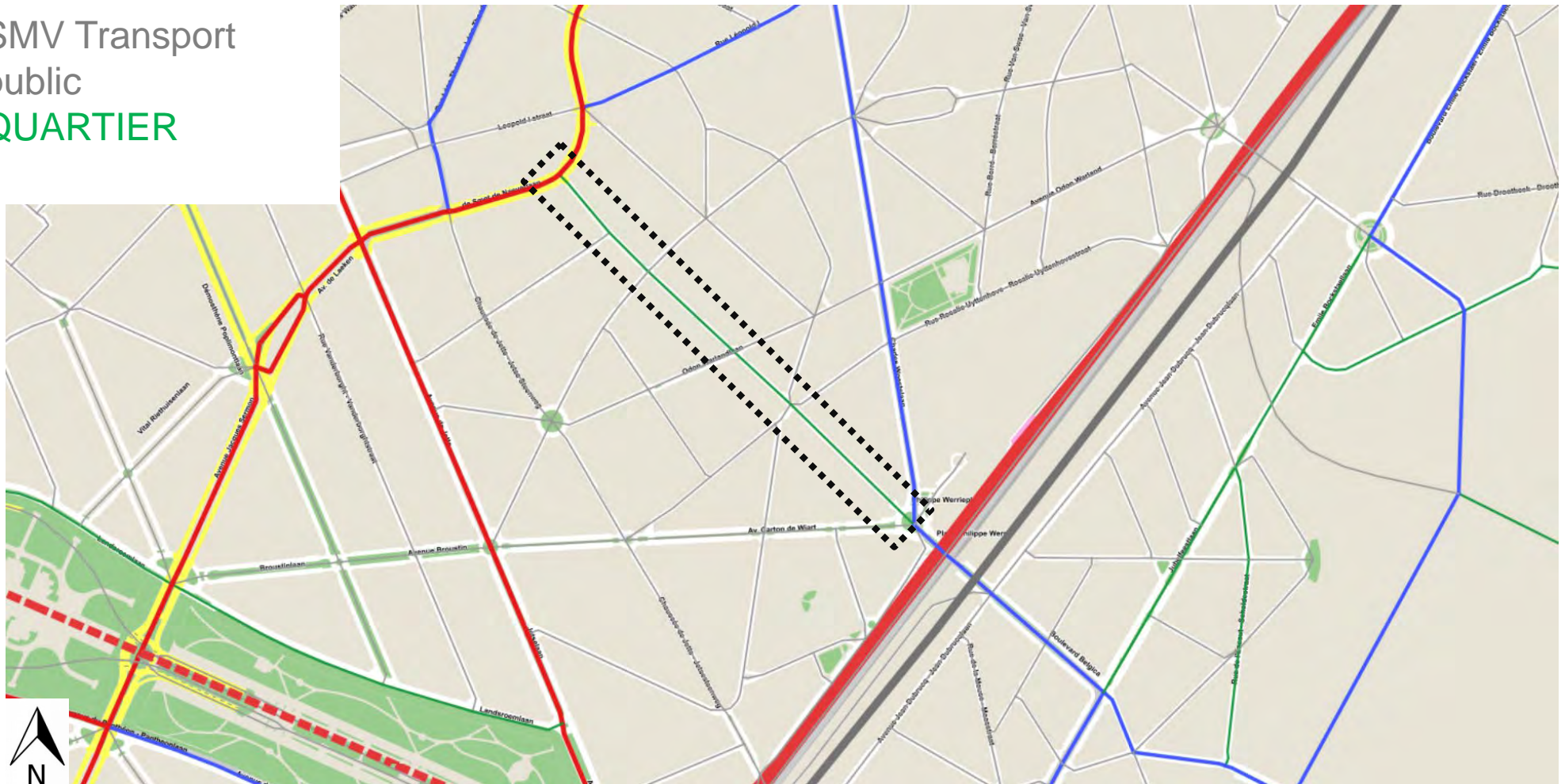

# Good Move

## Réseaux et trafic

SMV Auto  
QUARTIER

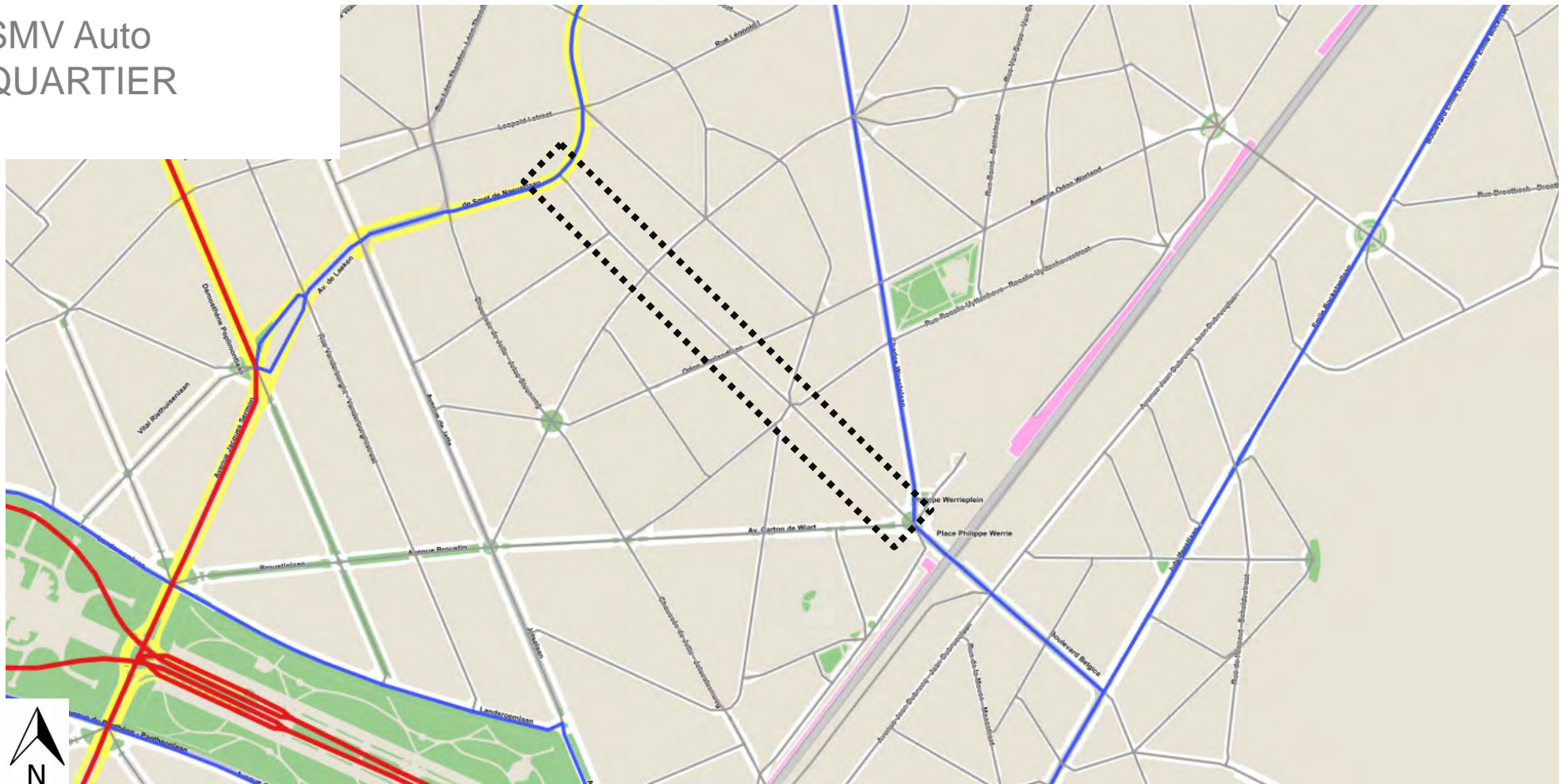

SMV - Mobigis



# Conclusion de l'étude de mobilité: Scénario retenu

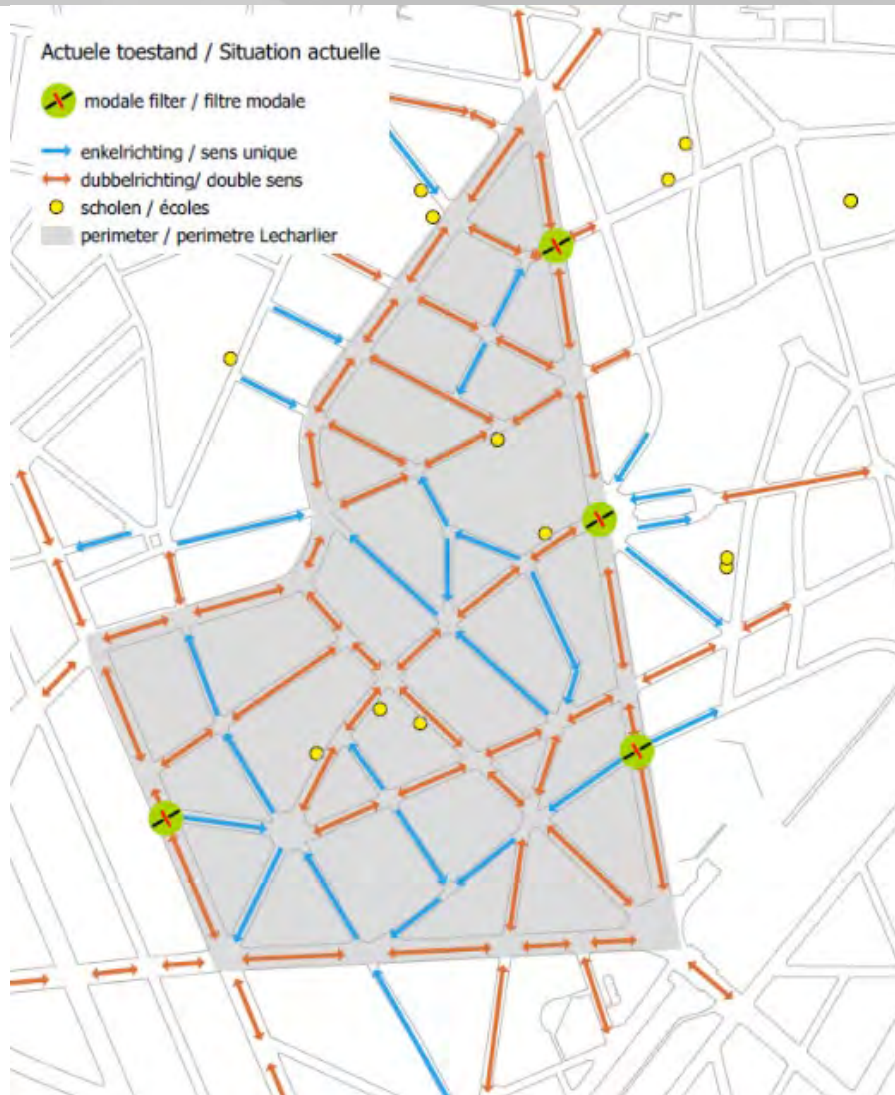

- Barrière rue scolaire
- Placette et filtre modal
- Mise à sens unique (sauf pour le bus sur Lecharlier)
- Changement de sens



# Vision des citoyens





- **Environnement vert et plus sain, quartier apaisé et lent;**
- **D'avantage de place pour les piétons en augmentant la sécurité pour laisser les enfants seuls dans l'avenue et en améliorant l'accessibilité pour les personnes plus âgées;**
- **D'avantage d'importance pour la marche, le vélo et les TP avec :**
  - des trottoirs confortables;**
  - des aménagements qui apaisent le trafic et sécurisent le déplacement des cyclistes;**
  - et des arrêts TP accessibles.**

# Requalification et amélioration du partage de l'espace sur l'avenue Firmin Lecharlier via:

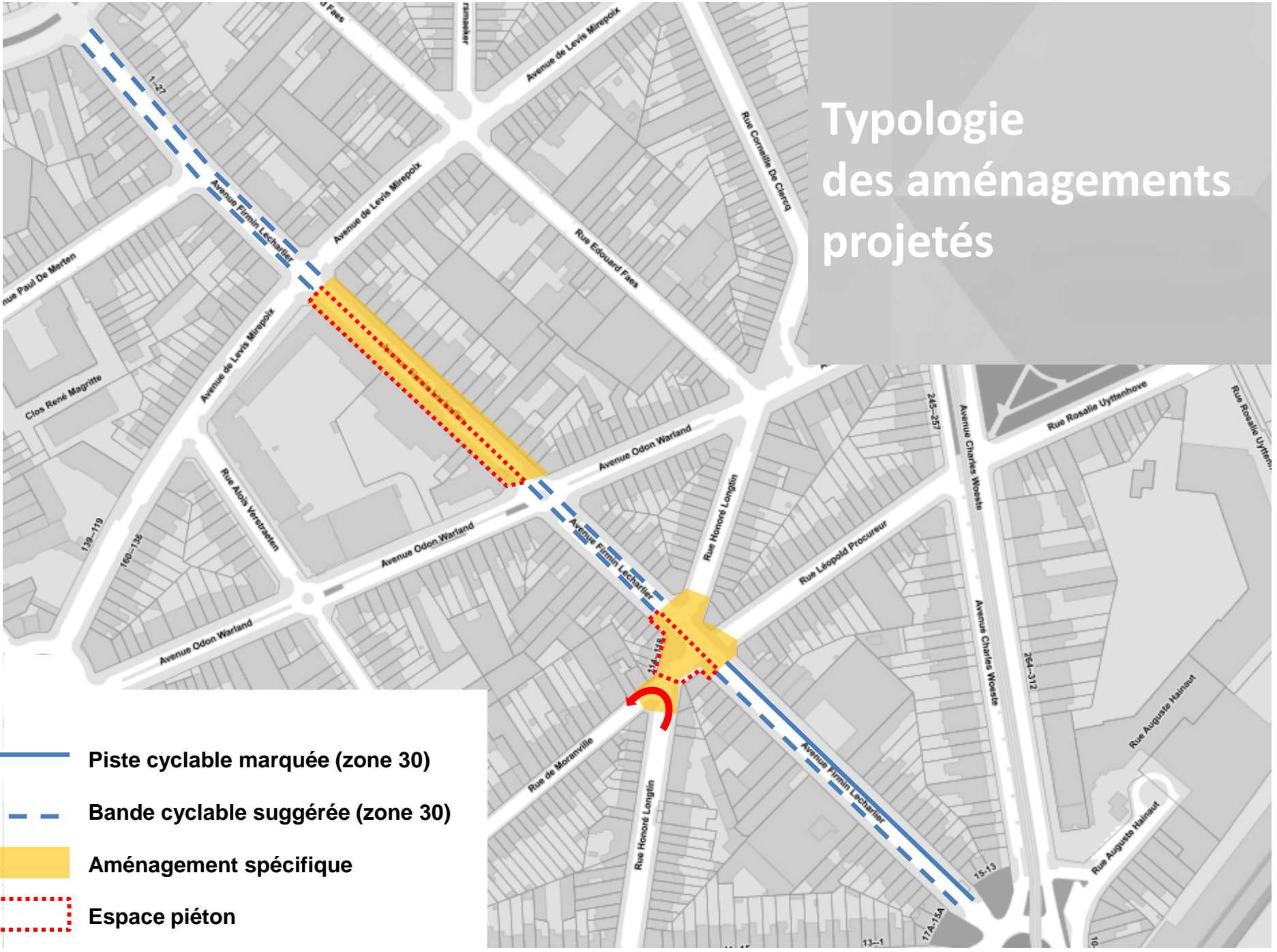
- **Un aménagement de qualité et sécuritaire en faveur des riverains et des usagers faibles;**
- **Une affirmation du caractère zone 30 et apaisé;**
- **Une fluidité du trafic et donc, en assurant la fluidité des lignes de bus dans le contexte zone 30**
- **Une diminution de la largeur de la chaussée en faveur des modes doux;**
- **Une gestion des eaux de ruissellement grâce à une restructuration complète de la voirie par des solutions d'aménagements spécifiques tout en renforçant les connectivités du maillage vert communal;**
- **Un renfort des principes Good Move.**

# Typologie des aménagements projetés



-  Piste cyclable marquée (zone 30)
-  Bande cyclable suggérée (zone 30)
-  Aménagement spécifique
-  Espace piéton

# Tronçon 1

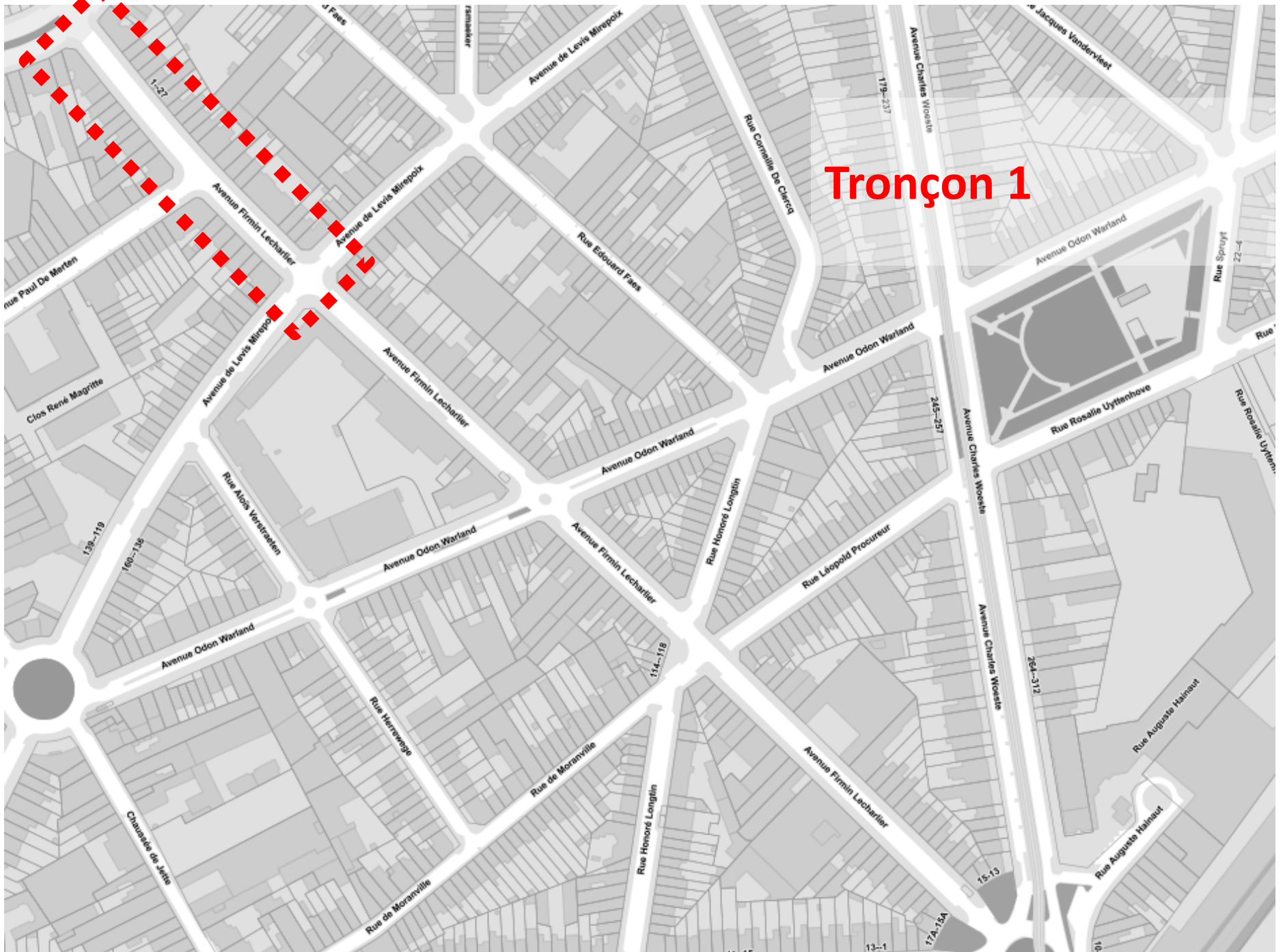

# Plan de la situation existante

## Tronçon entre Smet de Naeyer et Mirepoix



**Nombre de places de stationnement : 32** dont 2pl. Réservee  
aux personnes handicapées

**Nombre d'arbres : 26**



# Coupes de la situation existante

## Tronçon entre Smet de Naeyer et Mirepoix

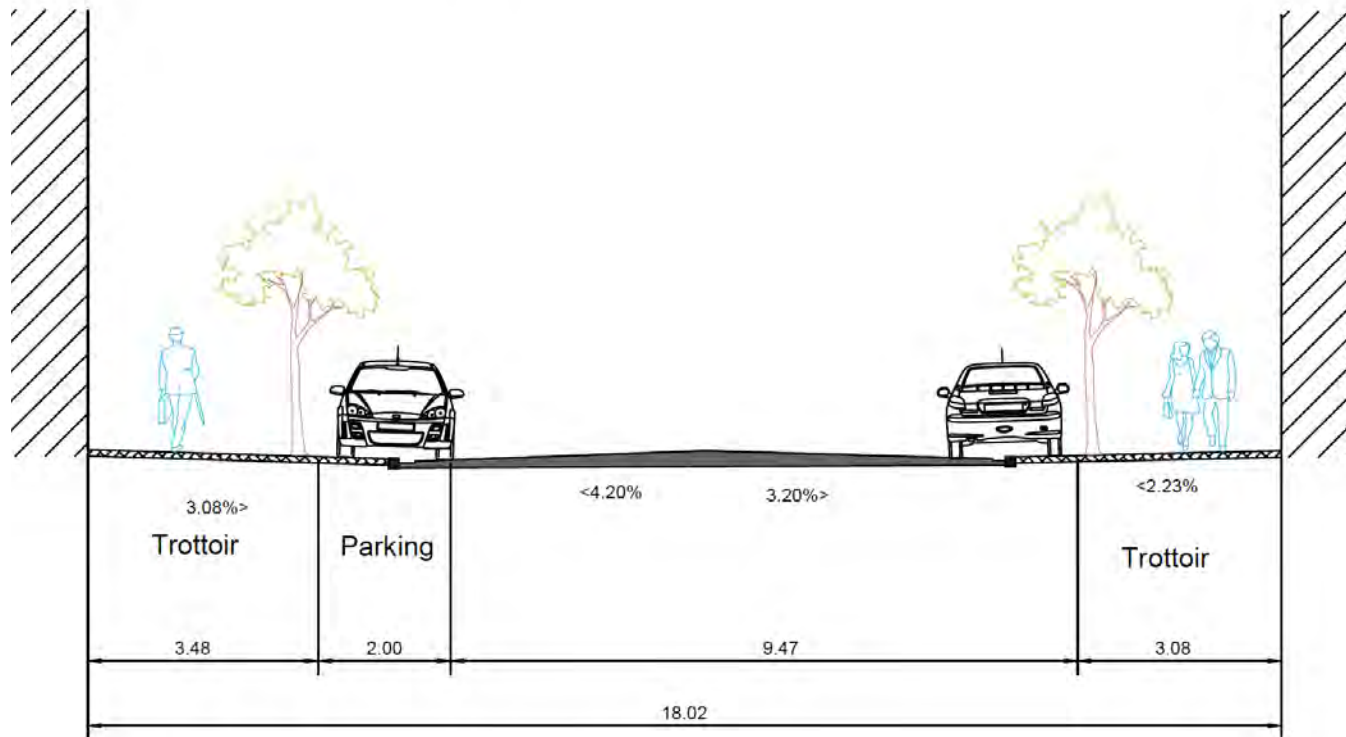

**Coupe F**

# Plan de la situation projetée

## Tronçon entre Smet de Naeyer et Mirepoix

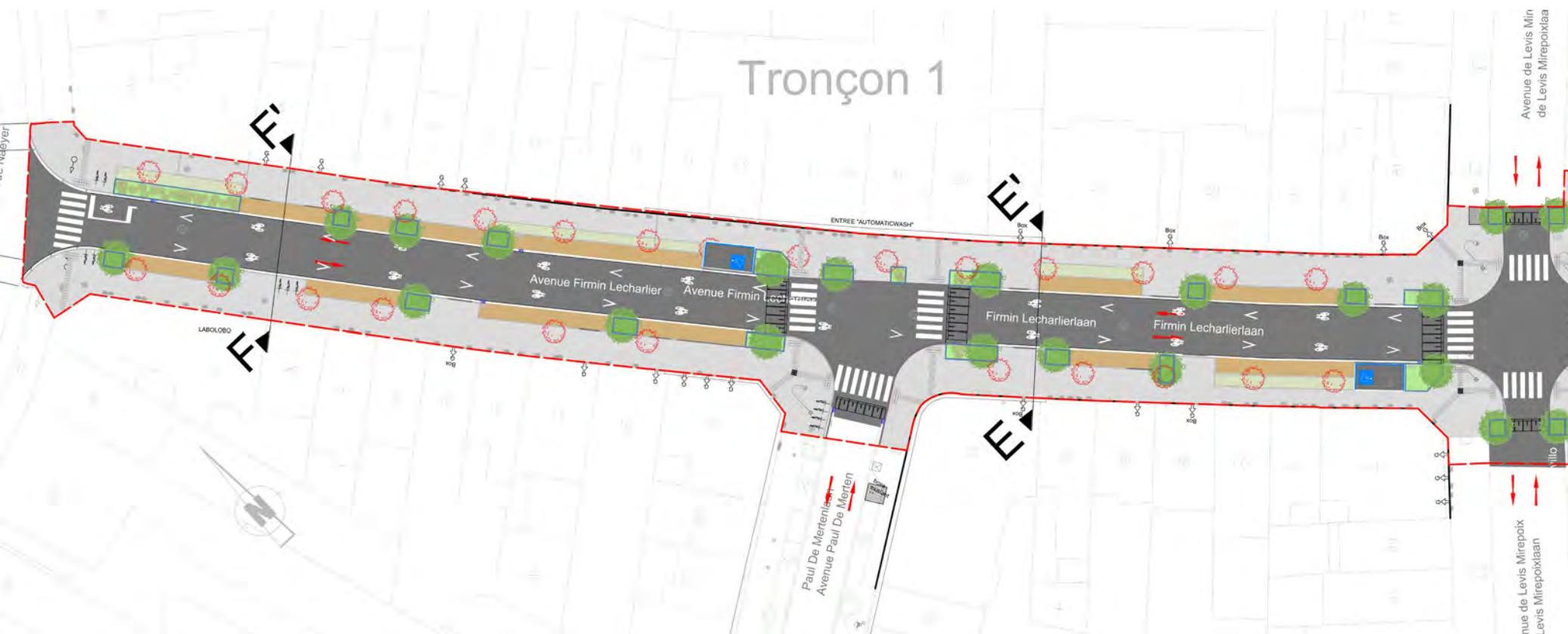

**Nombre de places de stationnement : 22** dont 2pl. réservées  
aux personnes handicapées

**Nombre d'arbre à planter : 22**





# Coupes de la situation projetée

## Tronçon entre Smet de Naeyer et Mirepoix

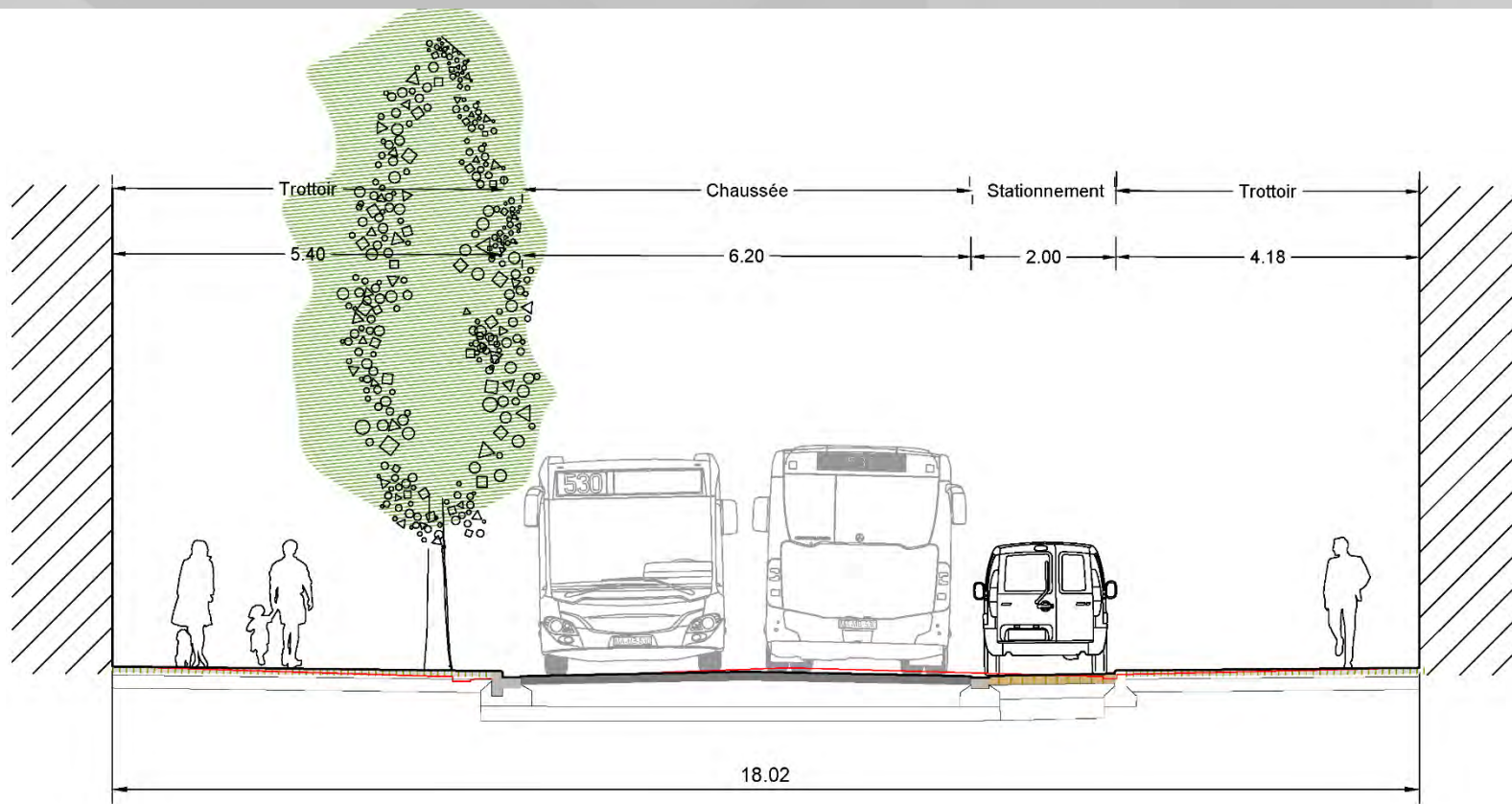

Coupe F

# Tronçon 2

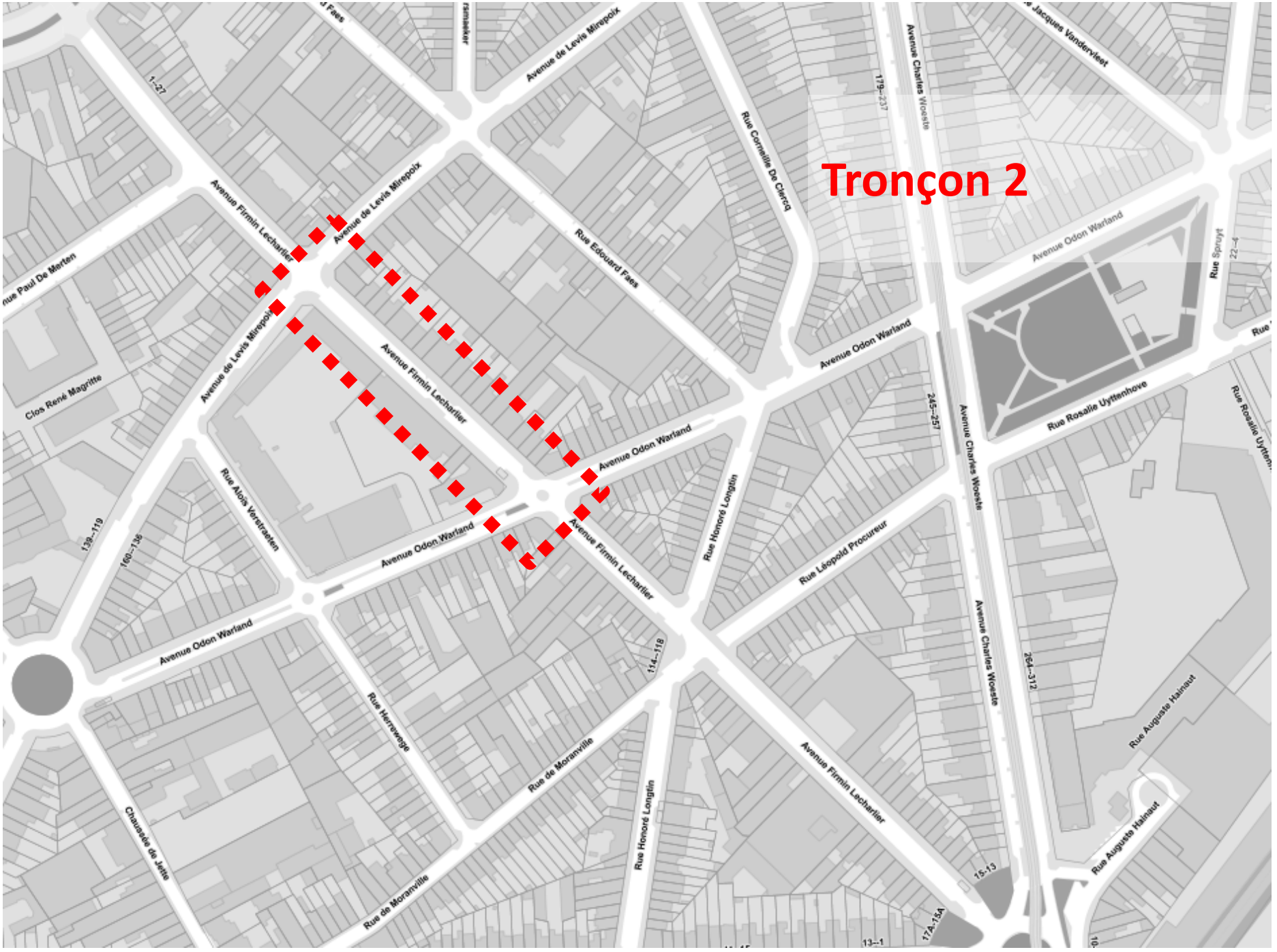

# Plan de la situation existante

## Tronçon entre Mirepoix et Odon Warland

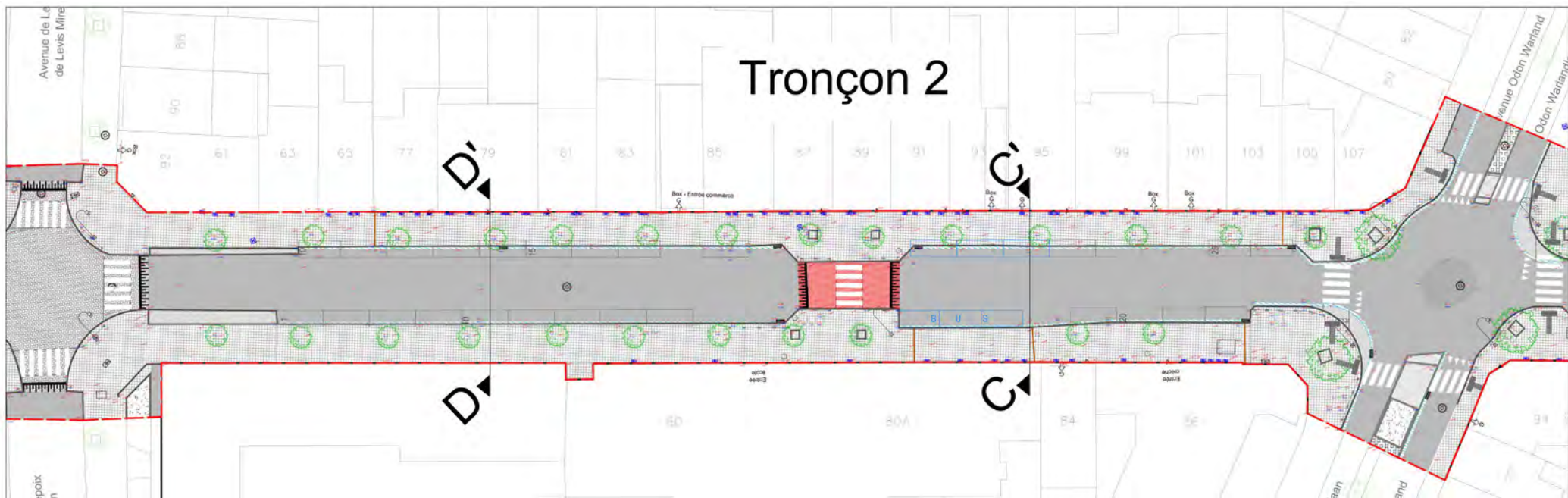

**Nombre de places de stationnement : 26 emplacements (+6)**  
**Nombre d'arbres : 27**



# Coupes de la situation existante

## Tronçon entre Mirepoix et Odon Warland

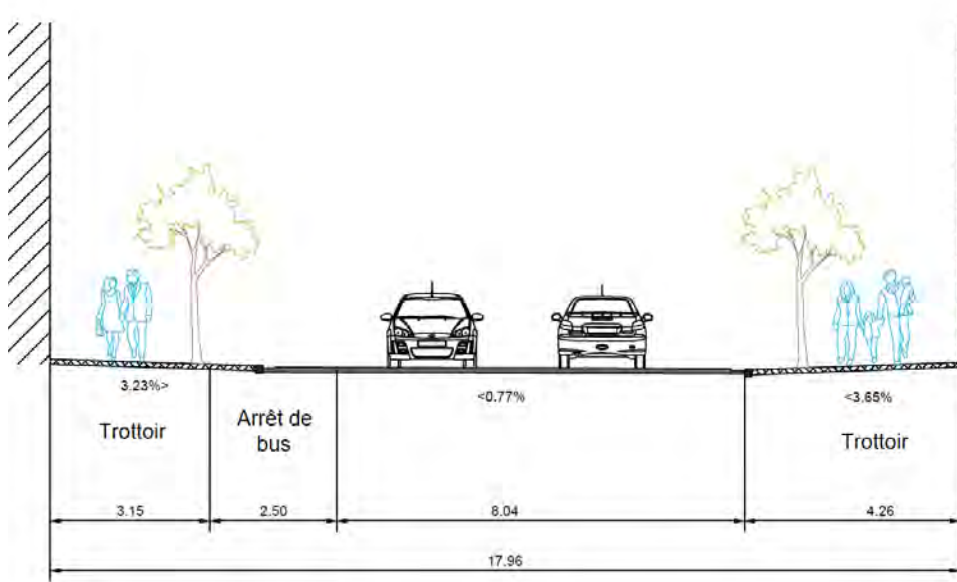

Coupe C

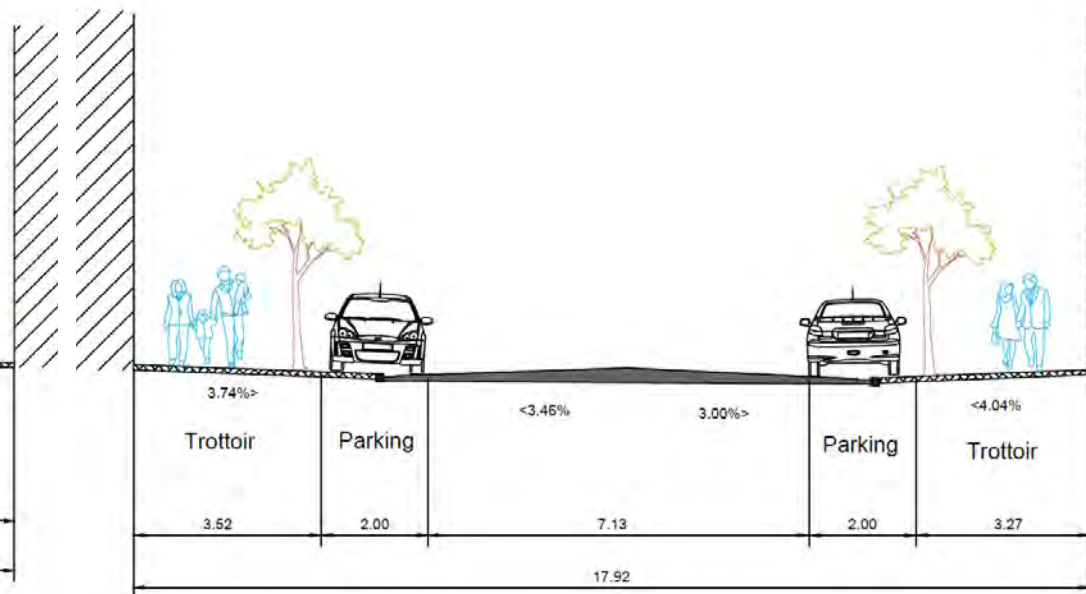

Coupe D

# Plan de la situation projetée

## Tronçon entre Mirepoix et Odon Warland

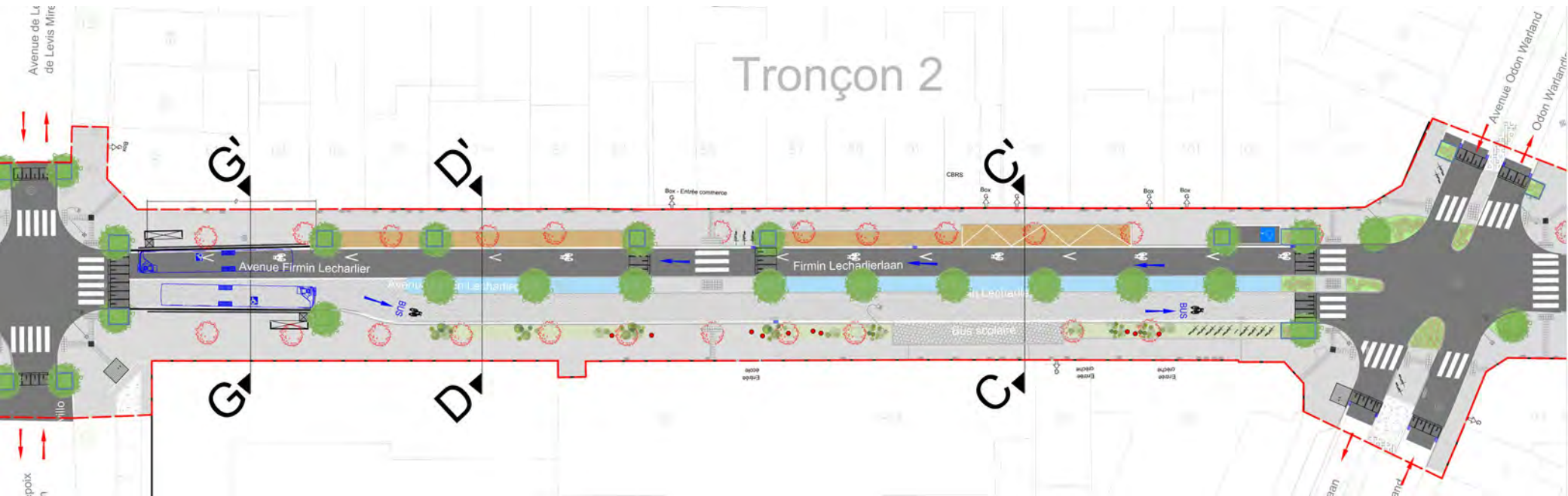

**Nombre de places de stationnement : 11 emplacements dont 1 réservée aux personnes handicapées (+3)**

**Nombre d'arbres à planter : 20**



# Coupe de la situation projetée

## Tronçon entre Mirepoix et Odon Warland

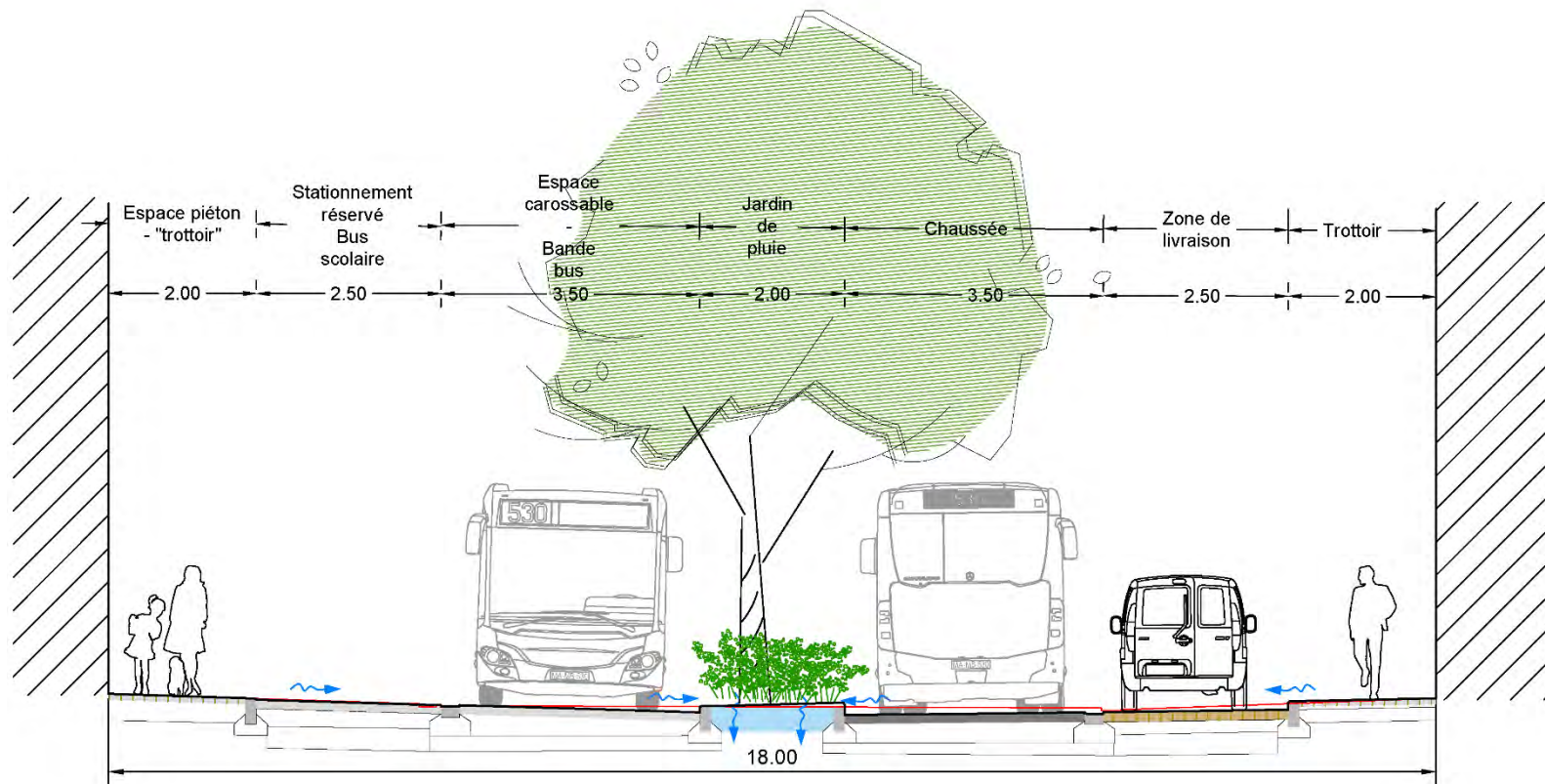

Coupe C

# Coupe de la situation projetée

## Tronçon entre Mirepoix et Odon Warland

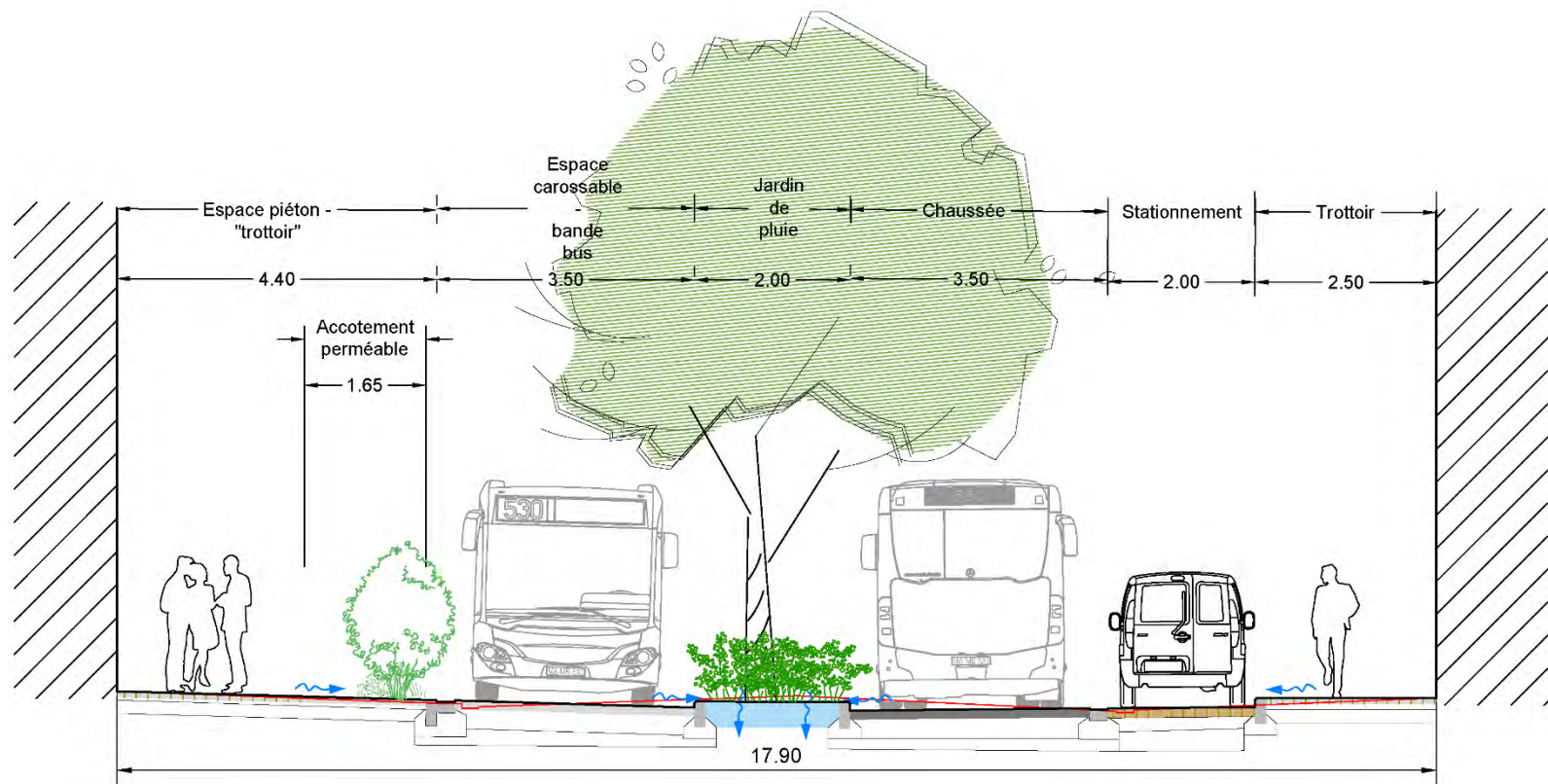

Coupe D

# Coupe de la situation projetée

## Tronçon entre Mirepoix et Odon Warland

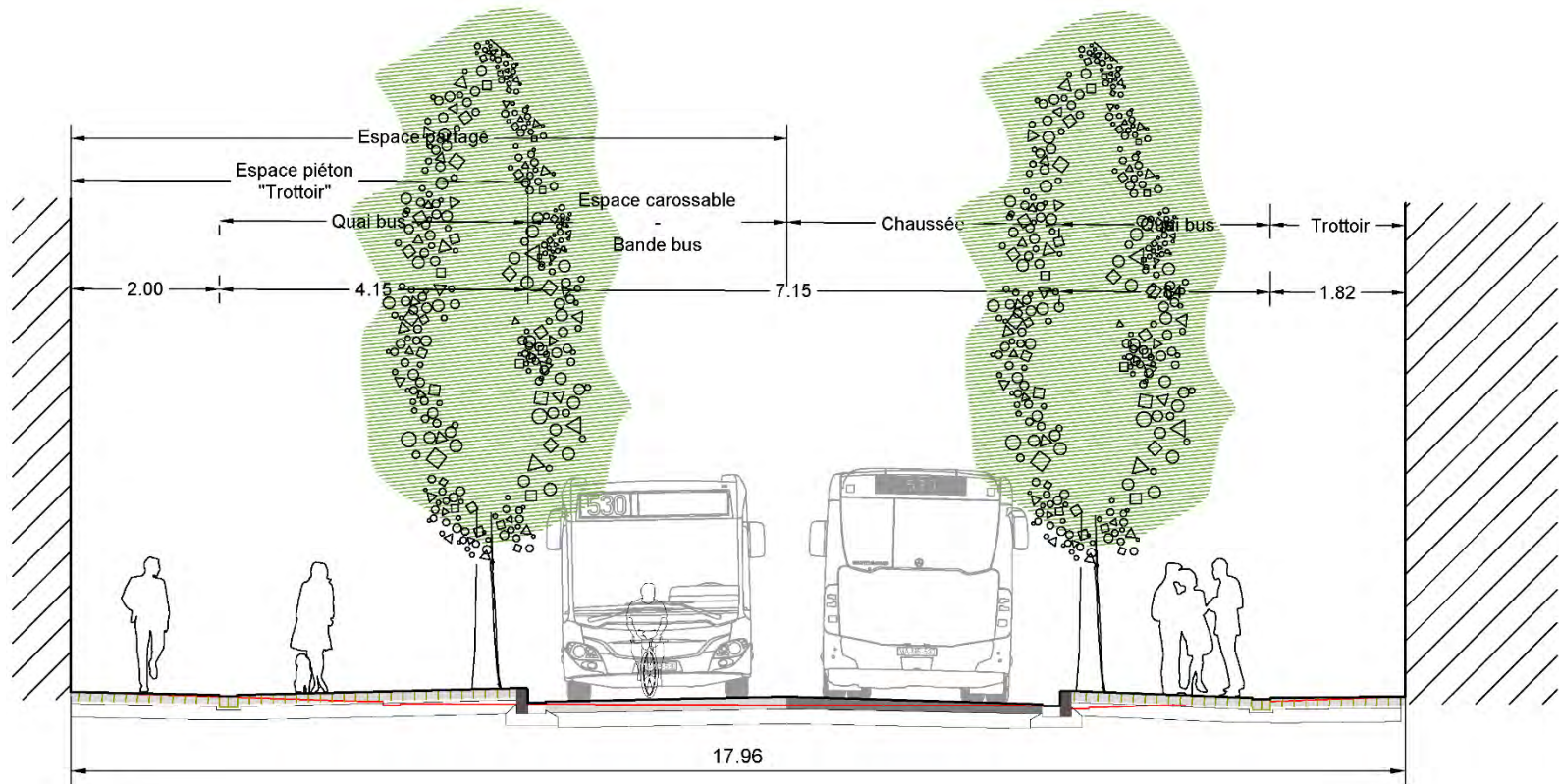

Coupe G



# Tronçon 3

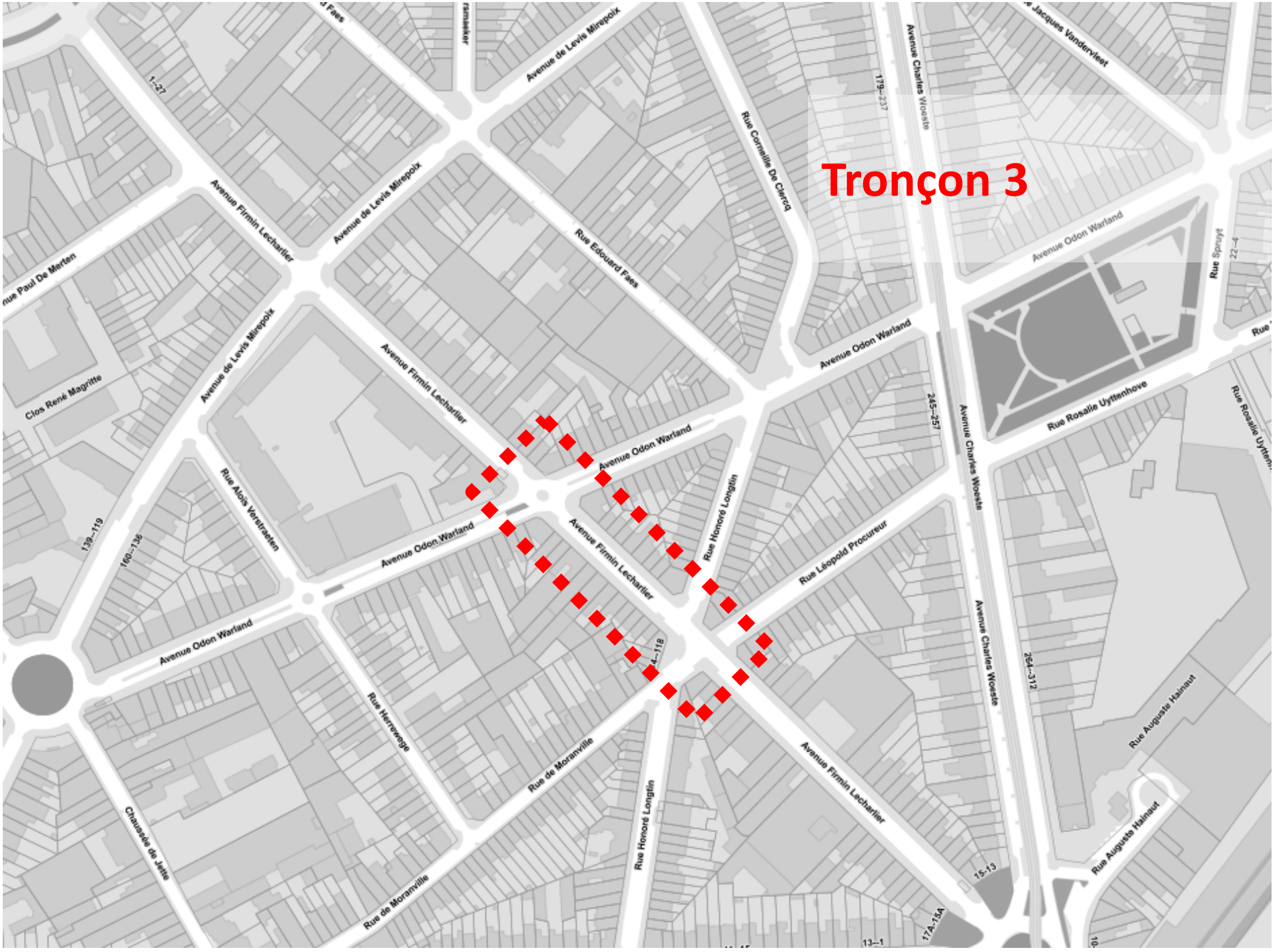

# Plan de la situation existante

## Tronçon entre Odon Warland et L Procureur

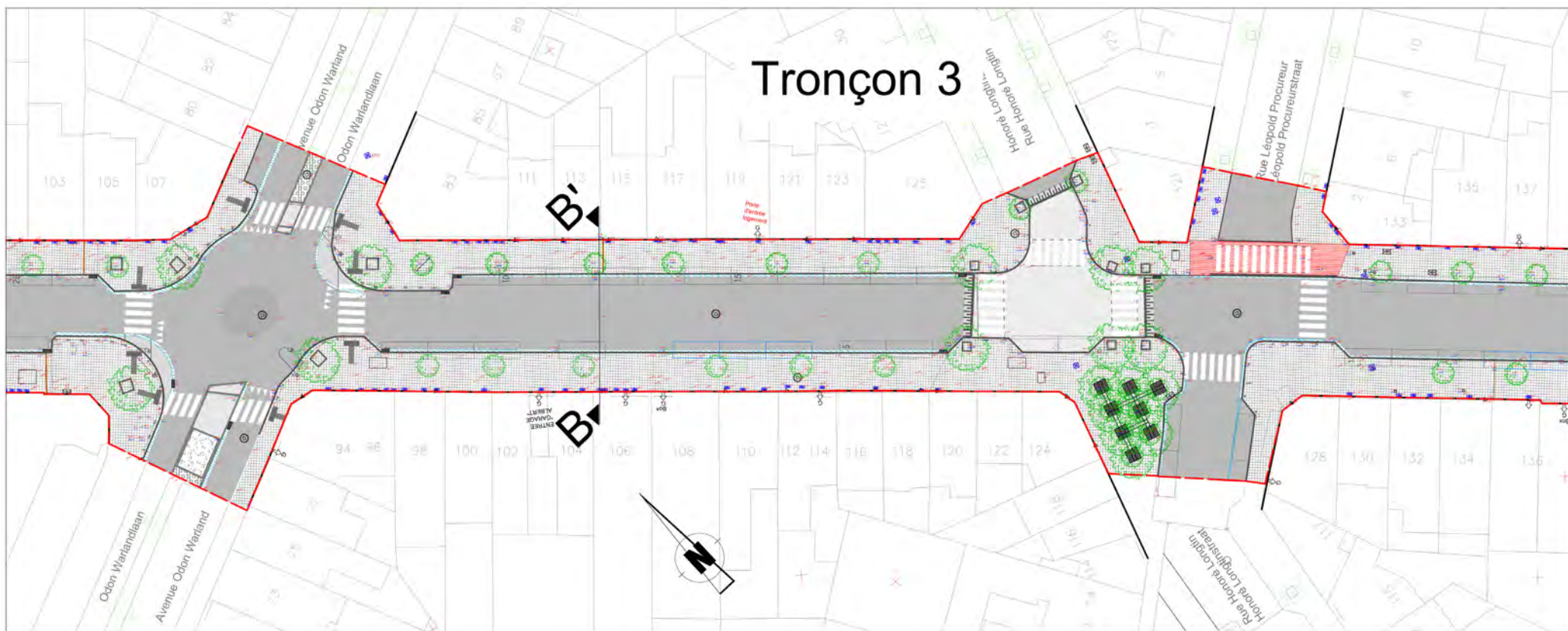

**Nombre de places de stationnement : 16+3 emplacements (+3)**  
**Nombre d'arbres : 30**



# Coupe de la situation existante

## Tronçon entre Odon Warland et L Procureur

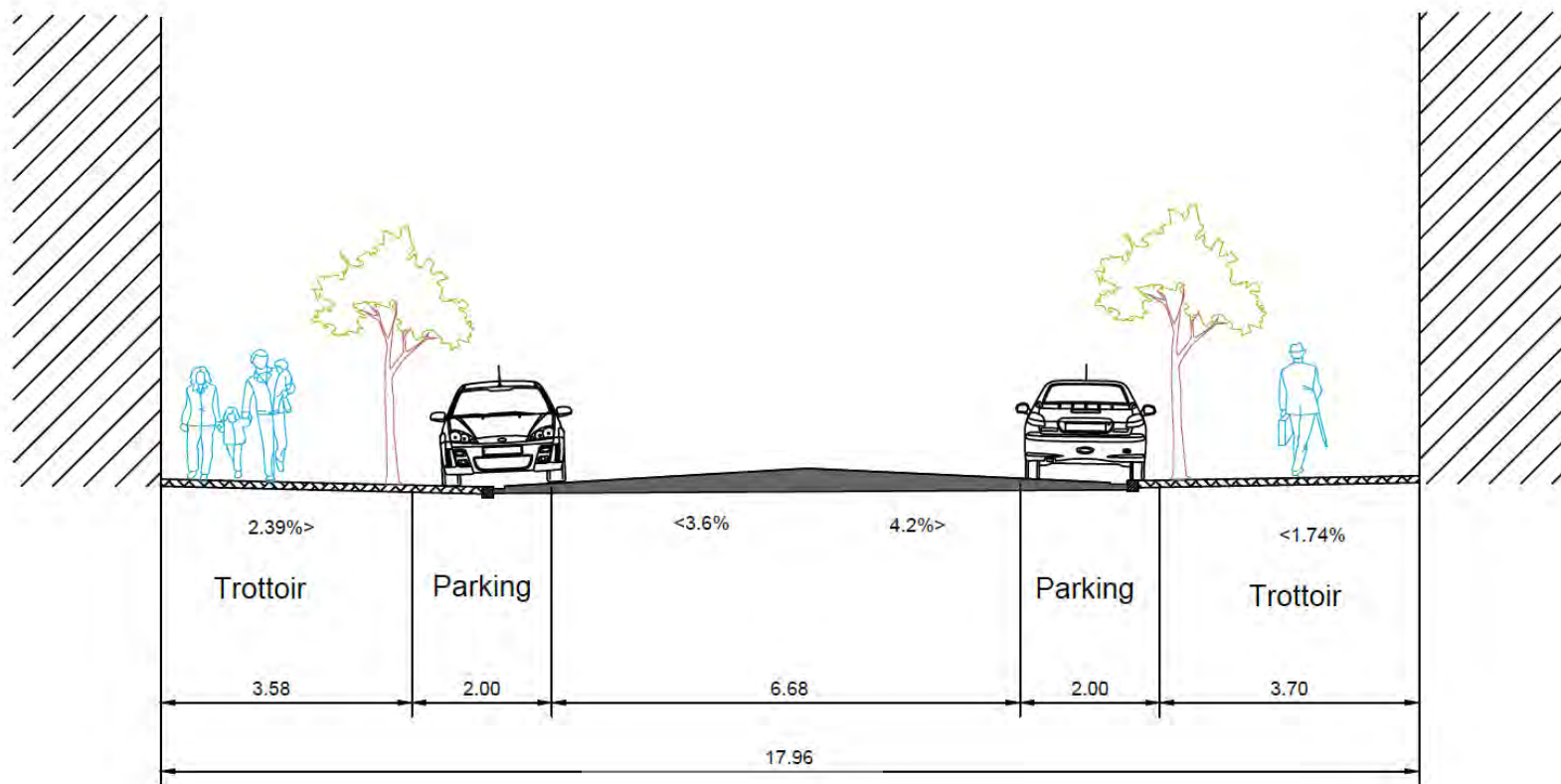

**Coupe B**

# Plan de la situation projetée

## Tronçon entre Odon Warland et L Procureur

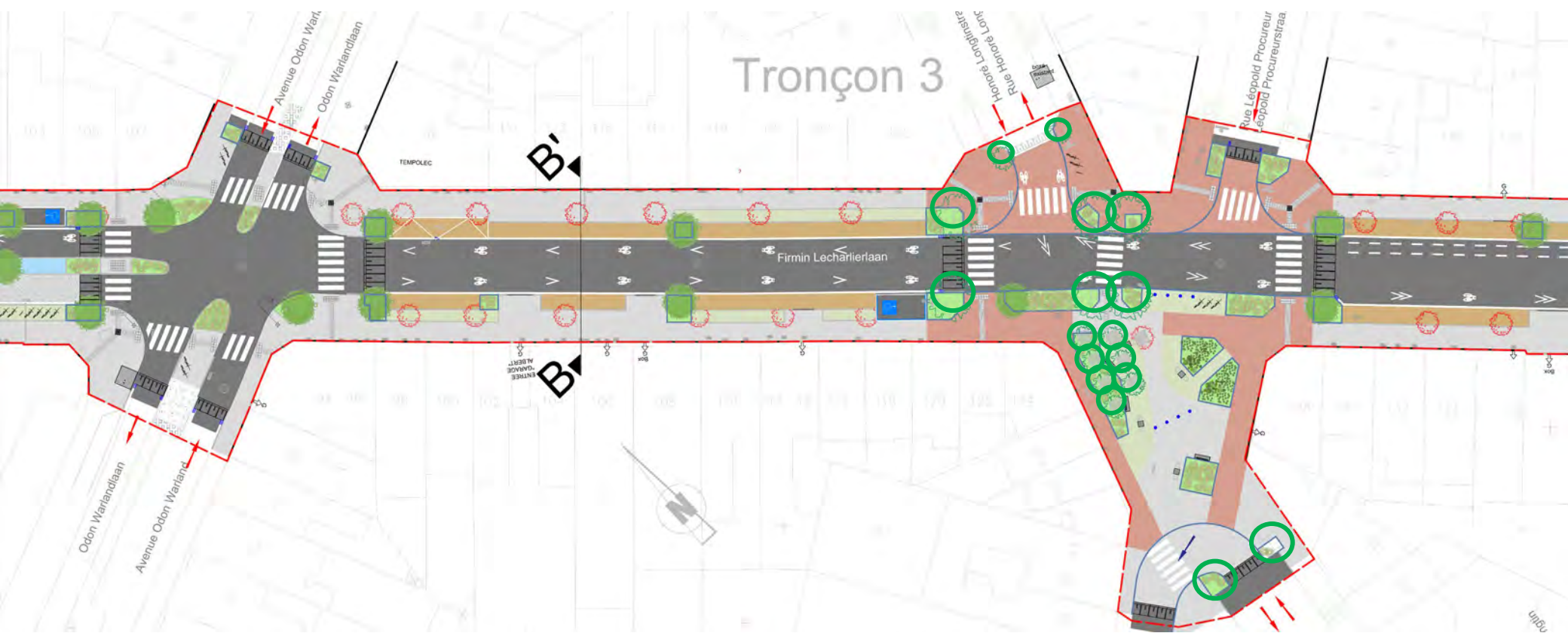

**Nombre de places de stationnement : 16 emplacements dont 1 réservée aux personnes handicapées (+2)**  
**Nombre d'arbres à planter : 5 (+ 17 arbres conservés)**



# Coupe de la situation projetée

## Tronçon entre Odon Warland et L Procureur

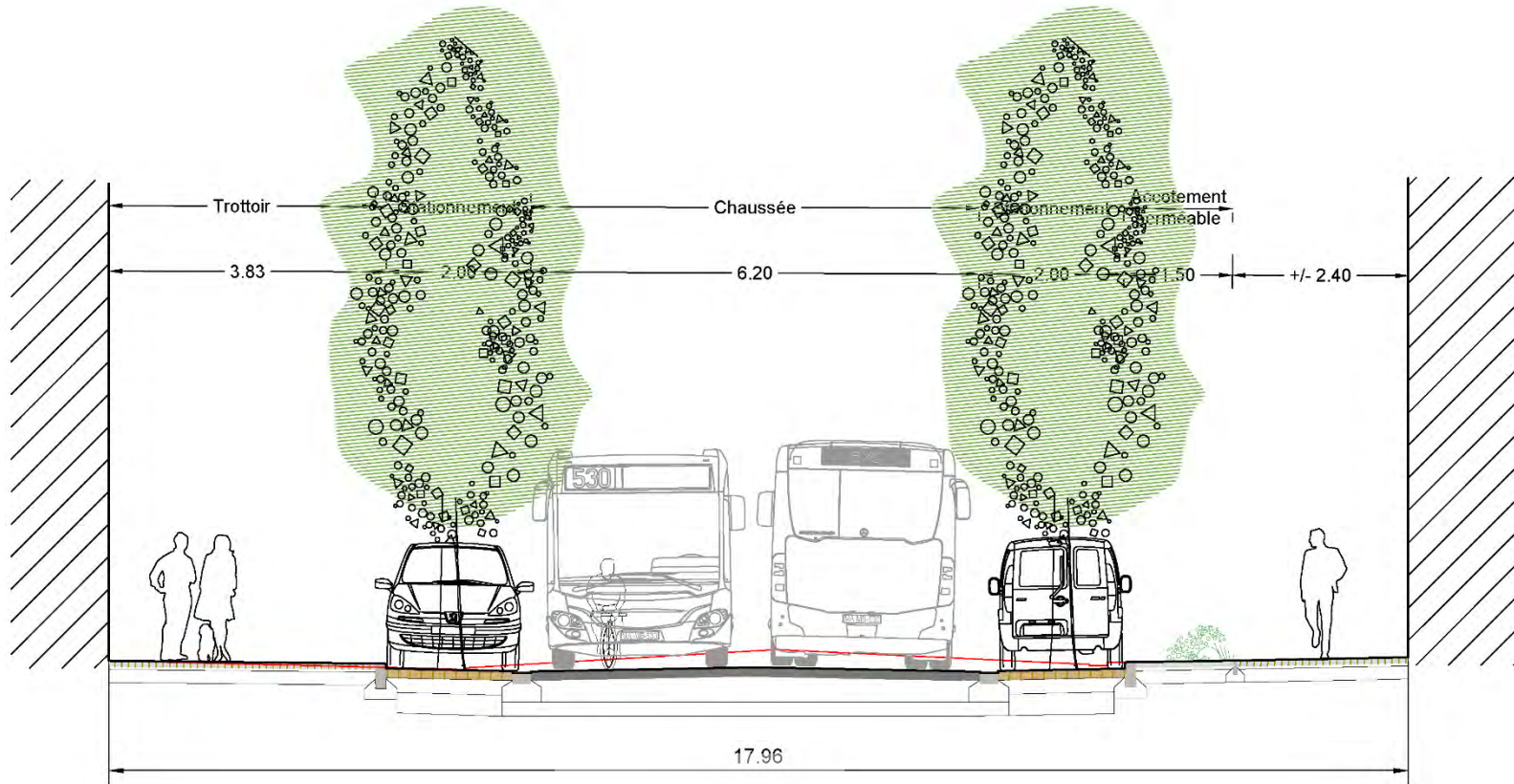

Coupe B

# Placette Honoré Longtin



# Placette Honoré Longtin



# Tronçon 4

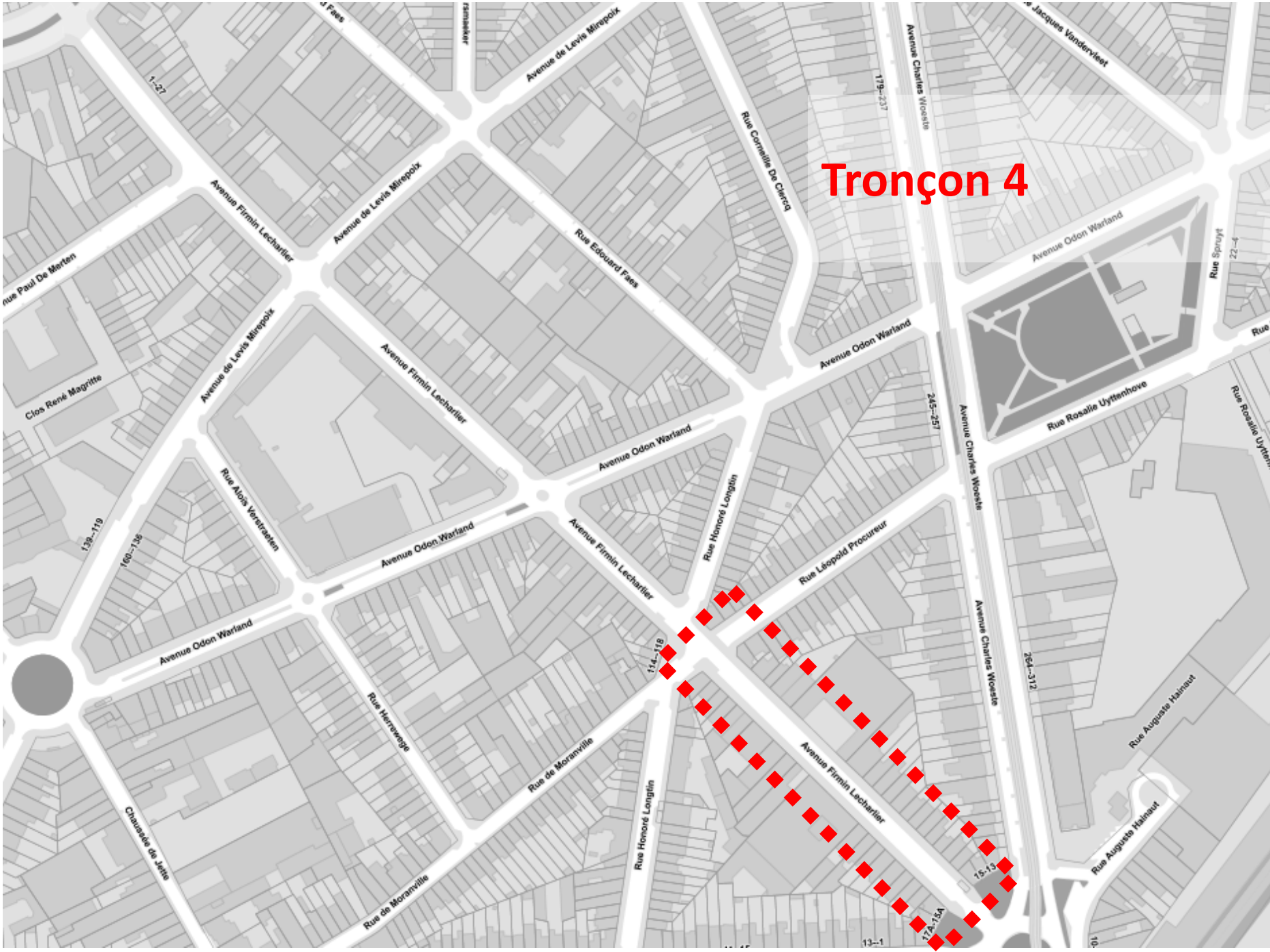



# Plan de la situation existante

## Tronçon entre L Procureur et Werrie

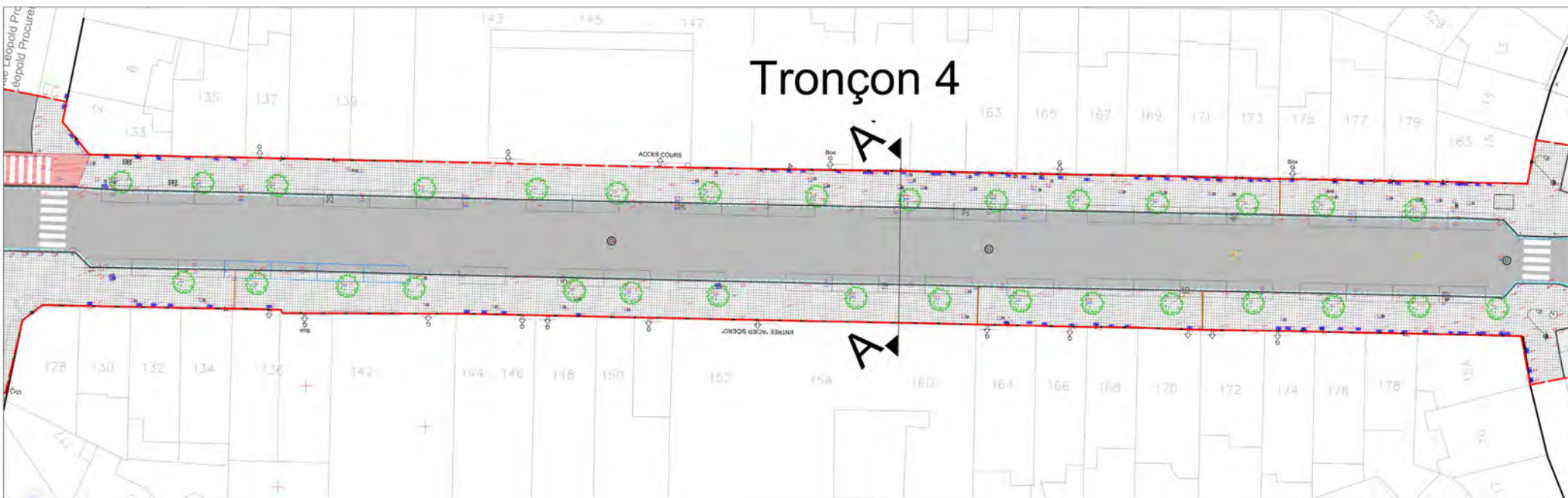

**Nombre de places de stationnement : 41 emplacements (+4)**  
**Nombre d'arbres : 31**



# Coupe de la situation projetée

## Tronçon entre L Procureur et Werrie

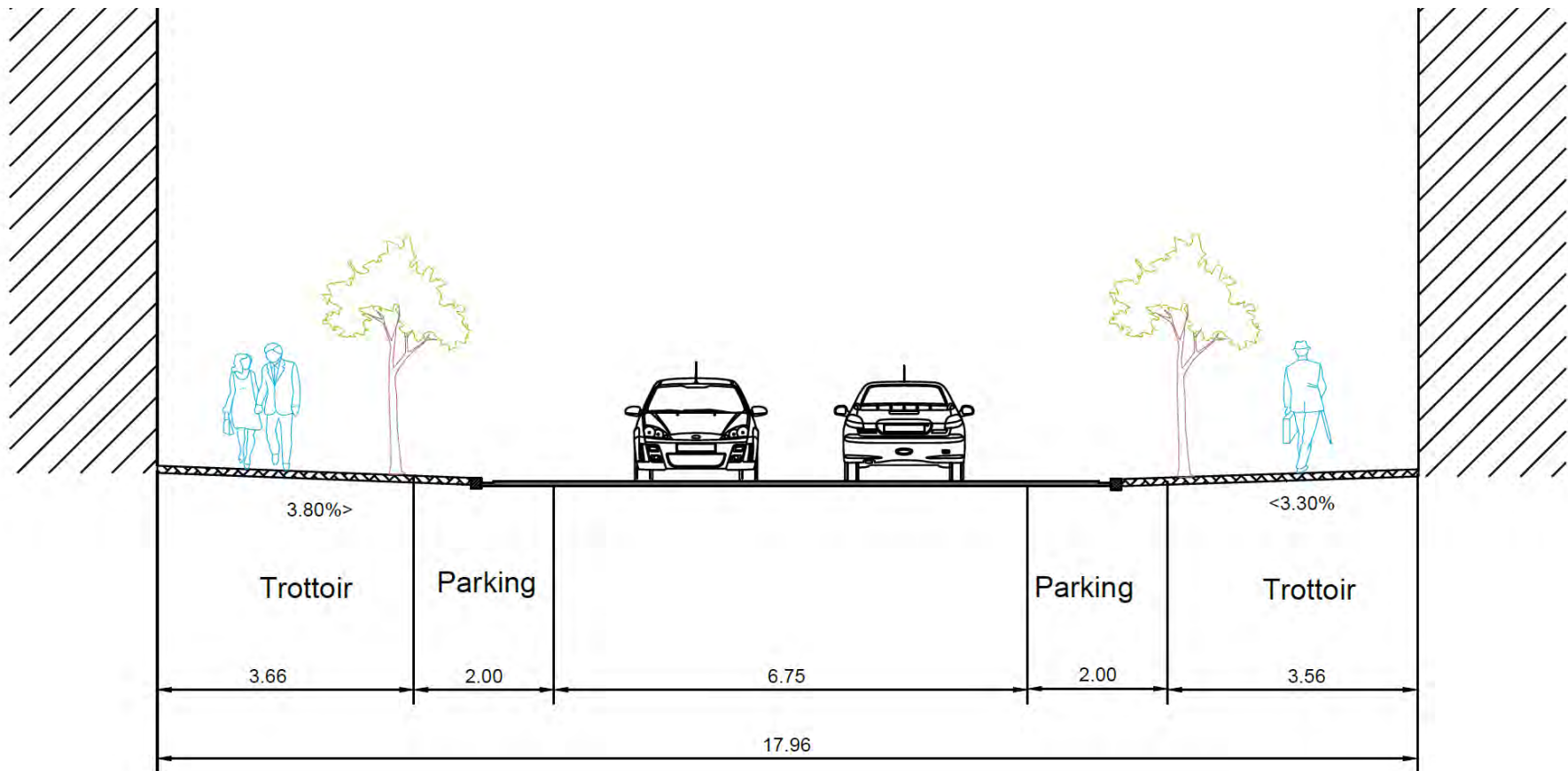

**Coupe A**

# Plan de la situation projetée

## Tronçon entre L Procureur et Werrie

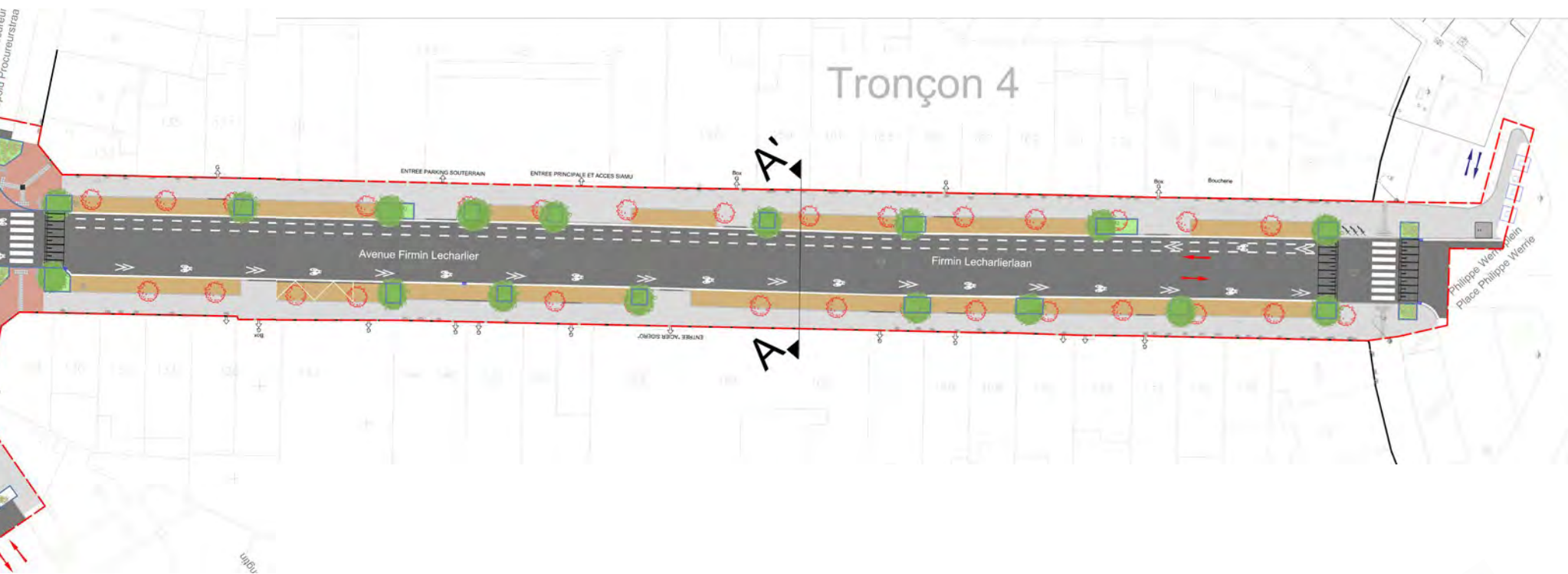

**Nombre de places de stationnement : 35 emplacements (+2)**

**Nombre d'arbres : 18**



# Plan de la situation projetée

## Tronçon entre L Procureur et Werrie

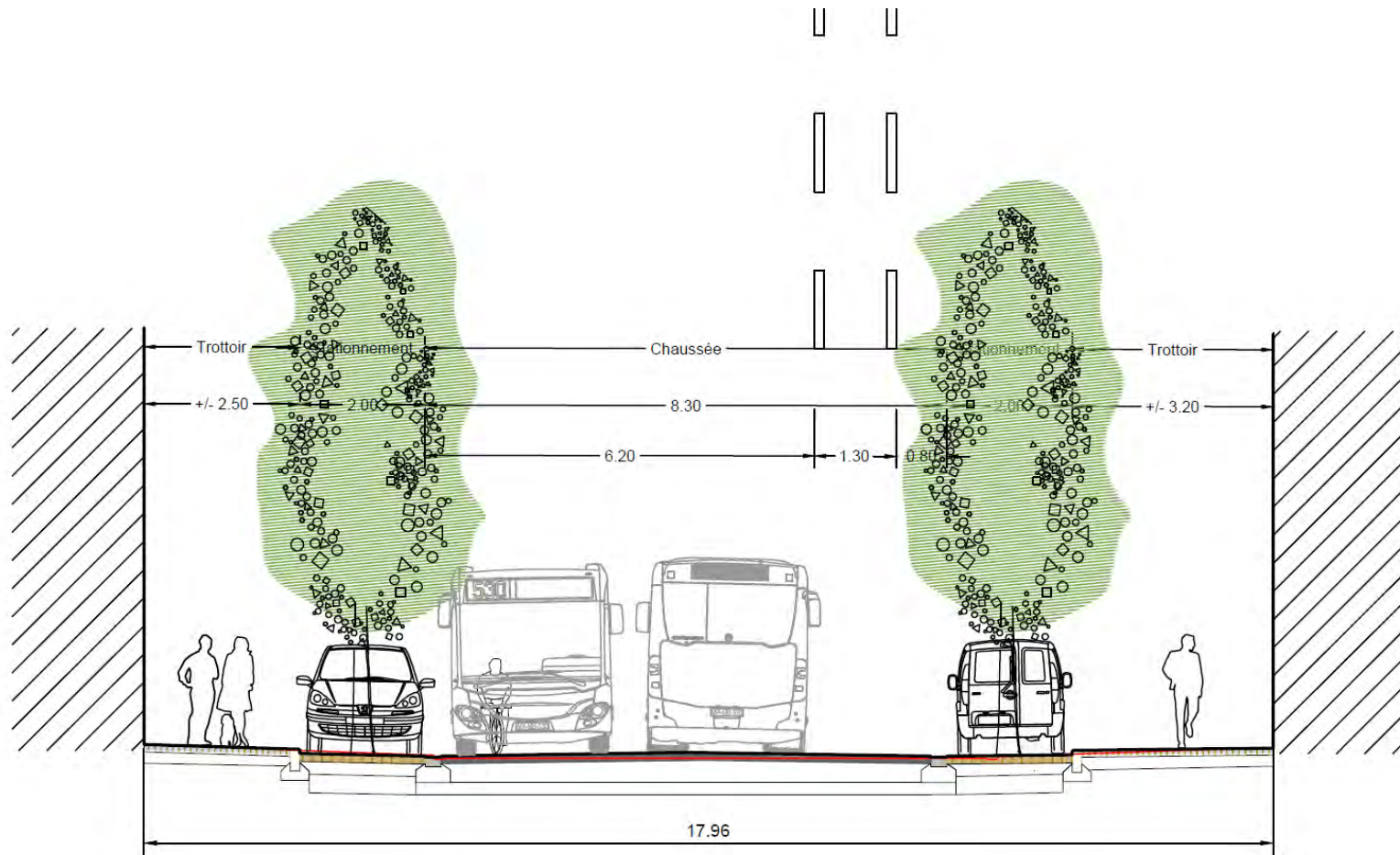

Coupe A

# Bilans stationnement et arbre

## Situation existante

		Emplacements légales	Emplacements devant garage	Emplacement personne handicapée	Emplacement zone de livraison	Emplacement bus	Totaux
Tronçon entre	Smet de Naeyer et Mirepoix	30		2			32
Tronçon entre	Mirepoix et Odon Warland	26			3	3	32
Tronçon entre	Odon Warland et Procureur	16			3		19
Tronçon entre	Procureur et Werrie	41			4		45
Rue	Honoré Longtin	3					3
		116		2			Total final = 131

## Situation projetée

		Emplacements légales	Emplacements devant garage	Emplacement personne handicapée	Emplacement zone de livraison	Emplacement bus	Totaux
Tronçon entre	Smet de Naeyer et Mirepoix	20	8	2			22
Tronçon entre	Mirepoix et Odon Warland	10	0	1	3		14
Tronçon entre	Odon Warland et Procureur	15	3	1	2		18
Tronçon entre	Procureur et Werrie	35	9		2		37
Rue	Honoré Longtin	0					0
		80	20	4			Total final = 91

111

Nombre d'arbres en situation existante = 114  
 dont 93 robiniers (diamètre de +/-1m et hauteur +/-3m) et 1 platane sont à abattre  
Nombre d'arbres en situation projetée = 82 dont 17 arbres aux essences variées sont conservés

# Traitement des eaux de pluie

Afin de limiter dans la mesure du possible l'évacuation directe des eaux de surface vers le réseau d'égouttage, l'aménagement pourrait favoriser :

- La percolation via les revêtements drainants et par l'extension des surfaces plantées ou les pieds d'arbres végétalisés

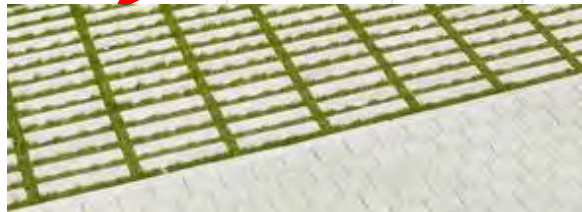

# Traitement des eaux de pluie – Jardin de pluie

- La rétention des eaux de pluie

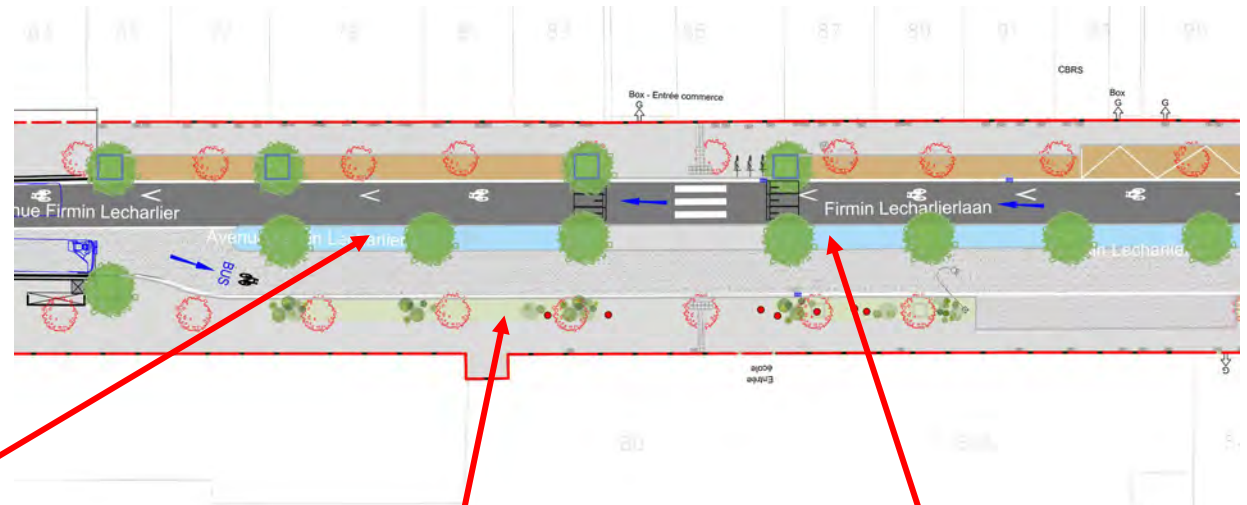



Matériaux

Zone 30





Bois - Entrée commerce

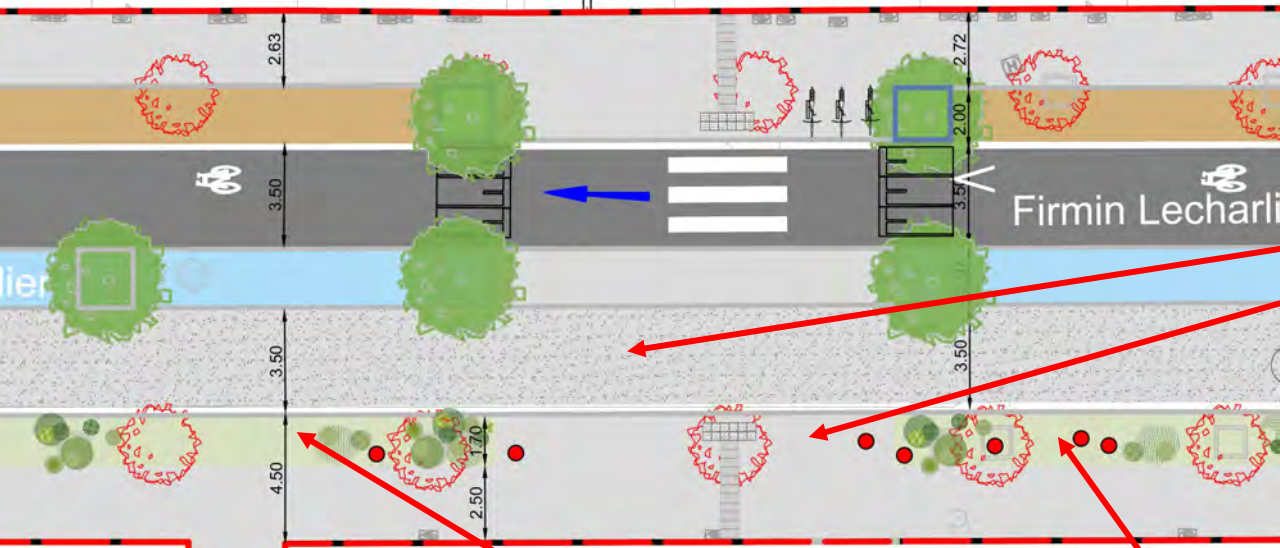

Firmin Lecharli

Entrée école

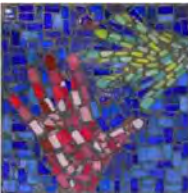

Matériaux

Zone 20





Carrefour rues Honoré Longtin  
#Edouard Faes # avenue Odon Warland



Matériaux

Placette Honoré



# Mobilier communal

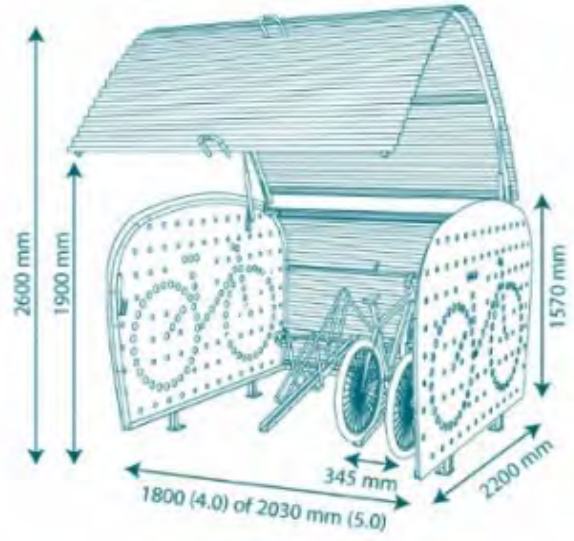



# Mobilier urbain spécifique

---

# Arbres



*Acer campestre* 'Queen Elizabeth'



*Acer rubrum* 'Scalon'



*Alnus spaethii* 'Spaeth'



*Carpinus betulus* 'A.Beeckman'



*Carpinus betulus* 'Frans Fontaine'



*Ilex aquifolium* 'J.C. van Tol'



*Liquidambar styraciflua* 'Worplesdon'



*Magnolia denudata* 'Yellow River'



*Parrotia persica* 'Bella'



*Prunus avium* 'Plena'



*Pyrus caleryana* 'Chanticleer'

# Massifs mélange d'arbustes, graminées et vivaces



*Nepeta fassenii*



*Geranium pratense*



*Centranthus ruber*



*Geranium sanguineum*



*Festuca glauca*



*Helleborus niger*



*Leucanthemum vulgare*



*Pachysandra terminalis*



*Pennisetum alopecuroides compressum*



*Stipa pennata*



*Molinia arundinacea*



*Verbena bonariensis*



*Alchemilla mollis*



*Heliochrysum italicum*



*Bergenia cordifolia*



*Rosa canina*



*Vinca minor*



*Hedera helix arborescens*

# Massifs mélange d'arbustes, graminées et vivaces



*Euonymus alatus compactus*



*Ribes rubrum* - Groseillier



*Fragaria vesca* - Fraisier des bois

## Plantation jardin de pluie



*Butomus umbellatus*



*Filipendula ulmaria*



*Iris pseudocorus*



*Juncus effusus*



*Lythrum salicaria*



**Merci pour votre attention**

